



September 1, 2021

MR RONALD BUELL
TOWN OF PHELPS
PO BOX 157
PHELPS WI 54555
[sent electronically only ronaldbuell@gmail.com]

MR ERIC CHRISTIANSEN
CM CHRISTIANSEN CO INC
PO BOX 100
PHELPS WI 54523
[sent electronically only cmc.co.inc@gmail.com]

SUBJECT: Technical Assistance/Interim Action Approval
C. M. Christiansen #1 – Pole Dip
Vilas County Parcel # 018-1391
DNR BRRTS Case #02-64-000068 & 07-64-582827

Dear Sirs,

On February 22, 2021, the Department of Natural Resources (DNR) received a request for technical assistance from MSA Professional Services (MSA) on behalf of the Town of Phelps. The request included a request form (DNR form 4400-237) and documents detailing proposed development activities at the former C. M. Christiansen #1 – Pole Dip site (Site), now owned by the Town of Phelps. The technical assistance fee to provide review and response, in accordance with Wisconsin Administrative (Wis. Admin.) Code chapter NR 749, was received on February 25, 2021.

The February 22, 2021 submittal included a development proposal for the Site by the Town of Phelps. The proposal details the construction of a snowmobile and all-terrain vehicle (ATV) trailhead consisting of a parking lot, access road and pit toilet. Additional information regarding the proposal was submitted to the DNR on June 9, 2021 and July 28, 2021.

The Site property was previously used as an industrial facility where discharges of hazardous substances, including pentachlorophenol (PCP), into the environment occurred. The development at the Site will open the property to public use. Due to this change in land use and the existing areas of known residual PCP contaminated soil, an additional interim remedial action in the form of fencing is proposed by the Town of Phelps to be further protective of human health and environment.

Approval for this interim remedial action lies in Wisconsin Statute (Wis. Stat.) § 292.12(2) and Wis. Admin. Code § NR 708.11(3). The DNR is pleased to inform you that the proposed interim remedial action is approved with conditions and continuing obligations (COs). The conditions and COs are legal requirements to limit potential exposure to existing contamination.

Summary of Environmental Conditions

C. M. Christiansen Company operated a pole dipping business between the mid-1950s until the early 1980s at the Site. Discharges of PCP, a wood preservative, mixed with a fuel oil carrier occurred on the Site during these years. In 1987, the DNR determined the C. M. Christiansen Co. Inc. was the responsible party associated with the environmental conditions at the Site. The Site was assigned the DNR Bureau of Remediation and Redevelopment Tracking System (BRRTS) number 02-64-000068. The entire property is approximately 23 acres; however, the Site is currently limited to approximately 5 acres in the northwest portion of the property. The proposed trailhead development is limited to approximately 2 acres in the far northwest portion of the Subject Property.

In the past 30 years, a variety of site investigation activities have occurred at the Site to determine the degree and extent of contamination to soil and groundwater in upland areas, and surface water and sediments in the adjacent Military Creek. The DNR has determined that the investigation and remediation of contamination to sediments in Military Creek has not been completed, so the Site remains “open” in terms of compliance with the requirements of Wis. Admin. Code chs. NR 700-799.

An interim remedial action occurred at the Site in the late 1990s. The remedial action included extraction and treatment/disposal of 18,000 gallons of contaminated groundwater and removal of 3,700 tons of contaminated soil/debris. Additionally, soil covers were placed over five (5) areas of residual contaminated soil. A Remedial Action Options Report submitted in 1998 by Natural Resource Technology, Inc. on behalf of C. M. Christiansen Co. Inc. indicated the soil covers were constructed to:

- Prevent direct contact;
- Reduce impacts to groundwater; and
- Reduce the potential for erosion.

A declaration of restrictions regarding the existing soil contamination was also attached to the property deed. The deed restriction applies to disturbing soil in the area of the soil covers. The deed restriction is included as part of an attachment to this correspondence.

Liability Clarification

In December 2018, the Town of Phelps requested clarification of environmental liability and a determination of local governmental unit (LGU) exemption provided by Wis. Stat. § 292.11(9)(e). Clarification of liability was provided to the Town by the DNR through a correspondence dated January 18, 2019 and is included as an attachment to this correspondence.

The January 18, 2019 correspondence from the DNR indicated the responsible party for the contamination at the Site is C. M. Christiansen Co. Inc. and that the LGU exemption would apply with conditions. Conditions include Wis. Stat. § 292.11(9)(e)(4) requirement of exempt LGUs to take actions the DNR determines necessary to reduce substantial threats to public health or safety. As the Town of Phelps is changing the land use of the Site from private industrial use to open public use, additional safeguards to health, safety and the environment are appropriate.

Proposed Development

The Town of Phelps is proposing to develop approximately 2 acres on the far northwest portion of the Site property. The proposed development is a snowmobile and ATV trailhead. A snowmobile/ATV trail currently traverses the property in the area of the proposed development.

The proposed development includes improving the access road, constructing a gravel parking lot, constructing a pit toilet and erecting fencing. Earthwork, including excavation and grading, will occur as part of the development. Plans of the proposed development were included with the request documents provided by MSA.

As previously stated, the soil covers were constructed over areas of PCP contaminated soil to prevent direct contact, reduce groundwater contamination and reduce erosion. The interim remedial action proposed by the

Town of Phelps is to construct a 4-foot chain link fence enclosing each of the existing soil covers as displayed on the attached Figure C-1.0, *Site Plan, Military Creek Trailhead Project*, prepared by MSA and dated May 14, 2021. Each of the fencing enclosures will require a locked gate to allow for cap maintenance. Signage will be placed on each enclosure indicating contaminated soil exists within the enclosures and access is prohibited.

Conditional Approval

Hazardous substance discharges have occurred at the Site. The DNR has concluded C. M. Christiansen Co. Inc. caused the discharges, and therefore is responsible for the contamination under Wis. Stat. § 292.11. On behalf of C. M. Christiansen Co. Inc., environmental consultant OBG submitted the *Site Investigation/Remedial Action Option Report* on August 11, 2017, and a second *Site Investigation/Remedial Action Option Report* on October 31, 2018, associated with contaminated sediments in Military Creek. In a letter dated August 12, 2020, the DNR stated that we were not approving the Site Investigation or the Remedial Action Option Report. The contaminated sediments in Military Creek remain an ongoing concern and the reason that this Site remains open.

In terms of the Town of Phelps' request, the DNR approves of the interim remedial action as proposed in the February 25, 2021 request and the subsequent June 9, 2021 and July 28, 2021 additional information submittals. The approval is granted with conditions and continuing obligations as per Wis. Stat. § 292.12(2).

Conditions of Approval and Continuing Obligations

Approval conditions are legally required conditions which include both COs and other requirements (Wis. Stat. § 292.12(2)). Under Wis. Stat. § 292.12(5), you, any subsequent property owners and occupants of the property must comply with the approval conditions as explained in this letter. The property owner must notify occupants for any condition specified in this letter under Wis. Admin. Code §§ NR 726.15(1)(b) and NR 727.05(2). If a party is responsible for maintenance of any approval condition specified in this letter, you and any subsequent property owner must include the condition in the lease agreement under Wis. Admin. Code § NR 727.05(3) and provide the maintenance plan to any occupant that is responsible.

Conditions of Approval

- The Town of Phelps has not or will not exacerbate the discharged hazardous substance.
- The Town of Phelps allows DNR personnel and C. M. Christiansen Co. Inc., its consultants and contractors access to the property to conduct necessary environmental monitoring and remedial action to fulfill its obligation under Wis. Stat. § 292 and Wis. Admin. Code chs. NR 700-799.
- The Town of Phelps, as the Property owner, complies with any conditions or obligations identified in DNR correspondences.
- The Town of Phelps will follow the development activities as proposed in the February 22, 2021, June 9, 2021 and July 28, 2021 submittals in that activities will occur as proposed in locations as proposed.
- The Town of Phelps will provide the DNR with an as-built construction documentation report within 60 days of completing the development of the trailhead.
- C. M. Christiansen Co. Inc. completes all actions necessary under Wis. Stat. § 292 and Wis. Admin. Code chs. NR 700-799, within a reasonable period of time, and obtains case closure for the Property.

CONTINUING OBLIGATIONS

Residual Soil Contamination (Wis. Admin. Code chs. NR 718, NR 500 to 599, and § NR 726.15(2)(b) and Wis. Stat. ch. 289)

Known soil contamination remains under the areas of soil cover as indicated on the attached map Figure C-1.0, *Site Plan, Military Creek Trailhead Project*. If soil in the locations shown on the map is excavated in the future, the property owner or right of way holder at the time of excavation must sample and analyze the excavated soil. If sampling confirms that contamination is present, the property owner or right of way holder at the time of excavation will need to determine if the material is considered solid waste and ensure that any storage, treatment

or disposal complies with applicable standards and rules. Contaminated soil may be managed under Wis. Admin. Code ch. NR 718 with prior DNR approval.

In addition, all current and future property owners, occupants and right of way holders need to be aware that excavation of the contaminated soil may pose an inhalation and direct contact hazard; special precautions may be needed to prevent a threat to human health.

Fencing (Wis. Admin. Code §§ NR 726.05(9), NR 726.15(2)(m), NR 727.07(7))

The Town of Phelps will install a 4-foot high chain link fence with locked access gates and signage around the five areas of soil cover as proposed in the February 22, 2021, June 9, 2021 and July 28, 2021 submittals from MSA, at the proposed locations shown on Figure C-1.0, *Site Plan, Military Creek Trailhead Project*. The fencing must be maintained to prevent access of the public onto areas of soil cover.

Pre-Approval Required for Well Construction (Wis. Admin. Code § NR 812.09(4)(w))

DNR approval is required before well construction or reconstruction for all sites identified as having residual contamination and/or COs. This requirement applies to private drinking water wells and high capacity wells. To obtain approval, the property owner is required to complete and submit Form 3300-254, Continuing Obligations/Residual Contamination Well Approval Application, to the DNR Drinking and Groundwater program's regional water supply specialist. A well driller can help complete this form. The form can be obtained online at dnr.wi.gov, search "3300-254." Additional casing may be necessary to help prevent contamination of the well.

Soil Cover (Wis. Stat. § 292.12(2)(a), Wis. Admin. Code §§ NR 724.13(1) and (2), NR 726.15(2)(d) and/or (e), NR 727.07(1))

As stated above, there are five areas of existing soil cover as shown on the attached map Figure C-1.0, *Site Plan, Military Creek Trailhead Project*. The purpose of the covers is to minimize the infiltration of water through contaminated soil and prevent direct contact with soil contamination that might otherwise pose a threat to human health and environment. A soil cover maintenance plan was not submitted for these five areas of cover during the previous remedial action approval process. As part of this current approval, C. M. Christiansen Co. Inc. shall submit a soil cover maintenance plan **by October 15, 2021**. The soil covers shall be maintained by C. M. Christiansen Co. Inc. in compliance with the maintenance plan. DNR guidance document RR-980 provides an example template for a cover maintenance plan; the document can be found online at dnr.wi.gov and entering "RR-980" in the Search bar.

To modify or replace a cover, the property owner must submit a request to the DNR under Wis. Admin. Code ch. NR 727. The DNR approval must be obtained before implementation. The replacement or modified cover must be a structure of similar permeability or be protective of the revised use of the property until contaminant levels no longer exceed Wis. Admin. Code ch. NR 720 groundwater pathway residual contaminant levels and/or direct contact residual contaminant levels (RCLs).

DNR NOTIFICATION AND APPROVAL REQUIREMENTS

Certain activities are limited at sites with COs to maintain protectiveness to human health and the environment. The property owner is required to notify the DNR at least 45 days before and obtain approval from the DNR prior to removing a cover or any portion of a cover (Wis. Admin. Code §§ NR 727.07, NR 726.15 (2), Wis. Stat. § 292.12(6)).

SUBMITTALS AND CONTACT INFORMATION

Site, case-related information and DNR contacts can be found online in the Bureau for Remediation and Redevelopment Tracking System (BRRTS) on the Web (BOTW); go to dnr.wi.gov and search "BOTW." Use the BRRTS ID # found at the top of this letter. The site can also be found on the map view, Remediation and Redevelopment Sites Map (RRSM) by searching "RRSM."

Send written notifications to the DNR using the RR Program Submittal Portal at dnr.wi.gov, search "RR submittal portal" (<https://dnr.wi.gov/topic/Brownfields/Submittal.html>). Questions on using this portal can be directed to the Project Manager below or to the environmental program associate (EPA) for the regional DNR office. Visit dnr.wi.gov, search "RR contacts" and select the EPA tab (<https://dnr.wi.gov/topic/Brownfields/Contact.html>).

In closing, the DNR looks forward to working with the Town of Phelps and C. M. Christiansen Co. Inc. to redevelop this Site for future use, and to complete the remaining actions necessary to bring this case to closure under Wis. Admin. Code ch. NR 726. If you have any questions regarding these issues, please contact the DNR Project Manager, John T. Hunt at (715) 701-9383 or johnt.hunt@wisconsin.gov. You can also contact me at (715) 208-4004 or christopher.saari@wisconsin.gov.

Sincerely,





Christopher A. Saari
Northern Region Team Supervisor
Remediation and Redevelopment Program

Attachments:

Figure C-1.0, *Site Plan, Military Creek Trailhead Project*, MSA, May 14, 2021
General Liability Clarification Letter, DNR, January 18, 2019

cc: Dick Lyster, MSA (dlyster@msa-ps.com)
Laurie Parsons, Ramboll, (laurie.parsons@ramboll.com)

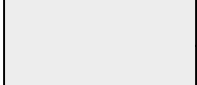
LEGEND

-  ASPHALT
-  GRAVEL
-  TURF GRASS



Shows typical Boundary of the five areas that will receive fencing to limit public access to area

11x17 1"=80'-0"
22x34 1"=40'-0"

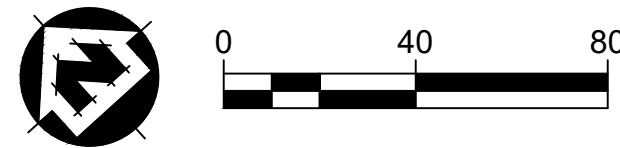

PROPOSED TRAILHEAD WORK

MONITORING WELL, TYP. OF (11)

PROJECT DATE:	DRAWN BY:	NO.	DATE	REVISION	BY:
	Init	-	-	-	-
	Init	-	-	-	-
	Init	-	-	-	-



ENGINEERING | ARCHITECTURE | SURVEYING
FUNDING | PLANNING | ENVIRONMENTAL
1230 South Boulevard, Baraboo WI 53913
(608) 356-2771 www.msa-ps.com
© MSA Professional Services, Inc.

MILITARY CREEK TRAILHEAD PROJECT
TOWN OF PHELPS
VILAS COUNTY, WI

SITE PLAN

PROJECT NO.
07558013
SHEET
C1.0