



April 22, 2024  
File: 193707141

**Attention: Mr. John Hunt**  
Hydrogeologist  
Wisconsin Department of Natural Resources  
Northern Region, Peshtigo Office  
101 North Ogden Road  
Peshtigo, Wisconsin 54157

**Reference: Passive Soil Venting System Abandonment Request (Former Amoco Barge Dock Property), C. Reiss Dock Property, Superior, Wisconsin. BRRTS Case No. 02-16-589248**

Dear Mr. Hunt,

Stantec Consulting Services Inc. (Stantec) prepared this letter to request approval to abandon the southern portion of an existing passive soil venting system present at the former Amoco Barge Dock Property located in Superior Wisconsin. Details related to the request are provided below. A fee in the amount of \$700 accompanies this letter for technical review by the Wisconsin Department of Natural Resources (WDNR).

### **Background Information**

The C. Reiss Coal Dock property in Superior, Wisconsin (herein referred to as the "Property") is in the east ½ of the northeast ¼ of Section 16 and the east ½ of the southeast ¼ of Section 09, Township 49 North, Range 14 West, Douglas County, Wisconsin. It is bordered by St. Louis Bay to the north, active industrial dock properties to the west and east, and the Burlington Northern Santa Fe Railway right-of-way to the south. The general location of the Property is illustrated on **Figure 1**.

The Property is currently associated with two open Bureau for Remediation and Redevelopment Tracking System (BRRTS) cases:

- 03-16-000320 MURPHY MARINE TERMINAL
- 02-16-589248 C REISS COAL DOCK PROPERTY

In addition, multiple BRRTS cases associated with the east-adjointing property have been documented as impacting soil and/or groundwater at the Property. These include:

- 02-16-297977 AMOCO OIL BARGE DOCK - FMR BARGE DOCK (closed),
- 02-16-297979 AMOCO BARGE DOCK - OW SEPARATOR & LOAD RACK (open), and
- 02-16-117873 AMOCO BARGE DOCK - MANIFOLD & AST AREA (open).

As part of historical environmental remediation activities associated with the open former Amoco Barge Dock BRRTS cases, a passive soil venting system was constructed along the western end of the former Barge Dock property. The venting system is constructed of a screened horizontal polyvinyl chloride (PVC) casing(s) located approximately three feet below grade and bedded in a soil/mulch mix. Every 100-200 feet, a twin set of solid PVC risers extend upwards, terminates above grade, and is topped with a passive "turbine" style vent. In total, there are 34 passive vents (PV-1 through PV-34). A schematic of the passive venting system is provided as **Attachment A**. The passive venting system is over 1,000 feet in length and terminates near a gated drive on the former Amoco Barge Dock property. The location of the vent system is illustrated on **Figure 2**.

Since mid-2023, construction activities at the Property have been ongoing to reestablish industrial bulk material handling operations at the Property by installing infrastructure for shipments by truck and rail as well as dock wall rehabilitation and sediment dredging. This month, further construction of the rail corridor on the Property and the southern end of the east-adjointing property, the former Amoco Barge Dock property, is planned. The route for the rail corridor will intercept the southern portion of the existing vent system.

### **Request for Approval**

On behalf of C. Reiss, Stantec is seeking approval from the WDNR to abandon up to six passive vents, PV-29 through PV-34 located the southern end of the passive venting system. The vents would be abandoned by complete removal of the PVC casing and turbines in this area. Remaining horizontal piping associated with the system would be capped with a PVC slip cap or similar apparatus to maintain the integrity of the remaining system. The abandonment would be documented by on-site personnel and a brief letter report documenting the abandonment would be provided following completion. Construction in this area is planned for the end of April 2024.

A fee, in the amount, of \$700, accompanies this report. We request the WDNR, review this request and provide approval to abandon PV-29 through PV-34.

We appreciate your consideration of this request. Should you have any question, please contact us.

Regards,

**STANTEC CONSULTING SERVICES INC.**



Stu Gross, PG  
Senior Project Manager  
[Stu.Gross@stantec.com](mailto:Stu.Gross@stantec.com)

### **ENCLOSURES**

#### **FIGURES**

Figure 1: Project Location and Local Topography  
Figure 2: Passive Soil Venting System Location Map

#### **ATTACHMENTS**

Attachment A: Passive Soil Venting System Schematic

## **FIGURES**



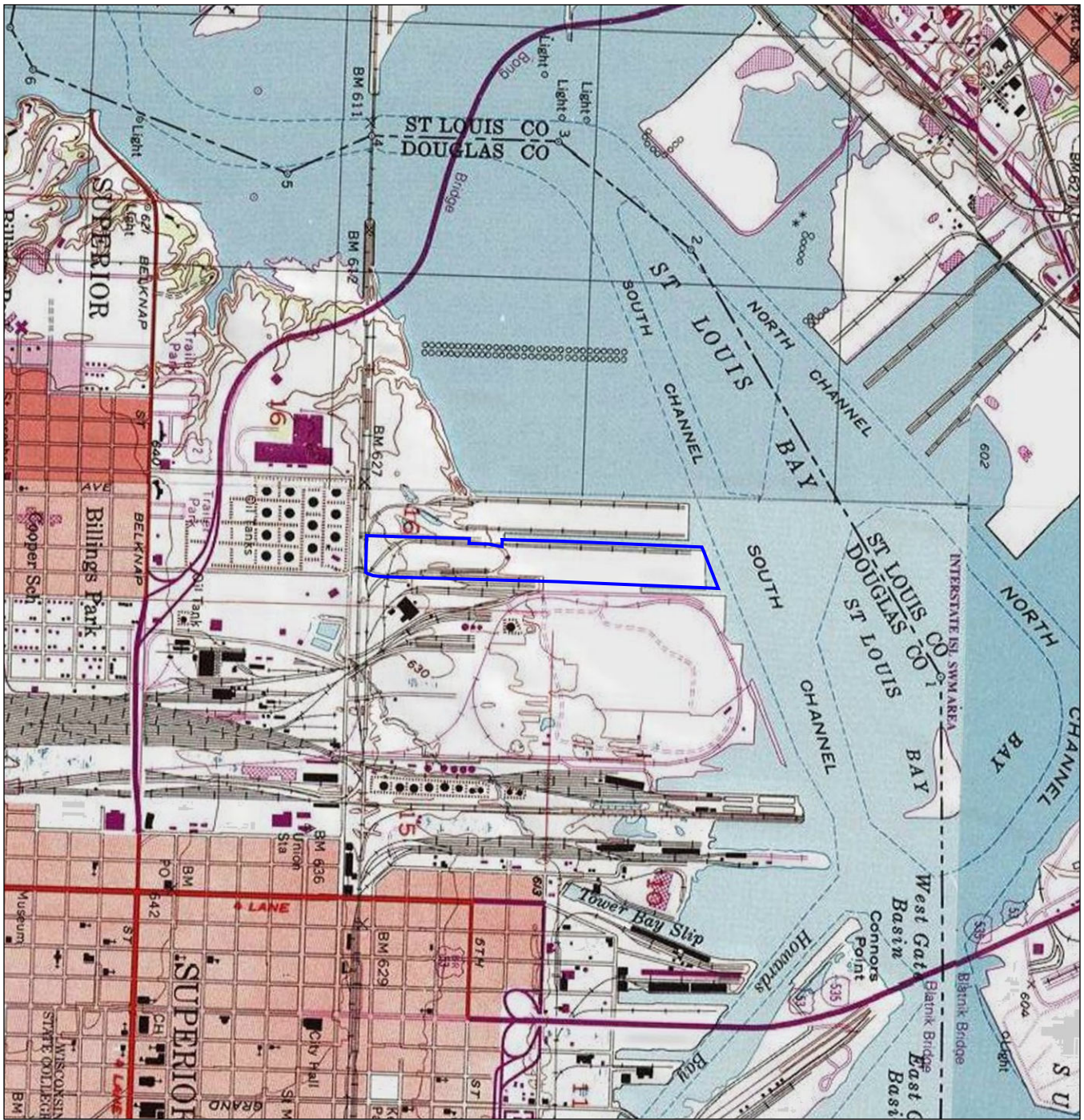

**Legend**  
 Project Boundary

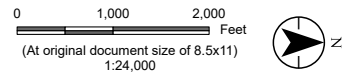

**Project Location** Prepared by AJIS on 2024-01-25  
 T49N, R14W, S09 & S16 TR by ML on 2024-01-25  
 C. of Superior, Douglas Co., WI IR by WC on 2024-01-26

**Client/Project** 193707141  
 The C. Reiss Company, LLC  
 C. Reiss Dock

**Figure No.**  
 1

**Title**  
 Project Location and Local Topography



Plot Date: 04/19/2024 - 3:24pm  
 Drawing name: C:\Users\craek\OneDrive\Documents\Stantec\Stantec Consulting\19390459\_River\_Paint\Project Files V\DOCUMENTS\CRESS.dwg SHEETS\Exhibits\WHP\193707141\MIWP2.dwg  
 Xref(s): B:\2022\MEG\193707141\SSR\193707141\_XSND\193707141\_SSR\193707141\_SSR\193707141\_SSR.dwg;Mech Overall Layout\201075\SCALE\NETWORK\Structuration\1-CON\NEWSHEETS\PL

THE CONTRACTOR SHALL VERIFY AND BE RESPONSIBLE FOR ALL DIMENSIONS. DO NOT SCALE THE DRAWING. ANY ERRORS OR OMISSIONS SHALL BE REPORTED TO STANTEC WITHOUT DELAY. NO USE FOR ANY PURPOSE OTHER THAN THAT AUTHORIZED BY STANTEC IS FORBIDDEN.

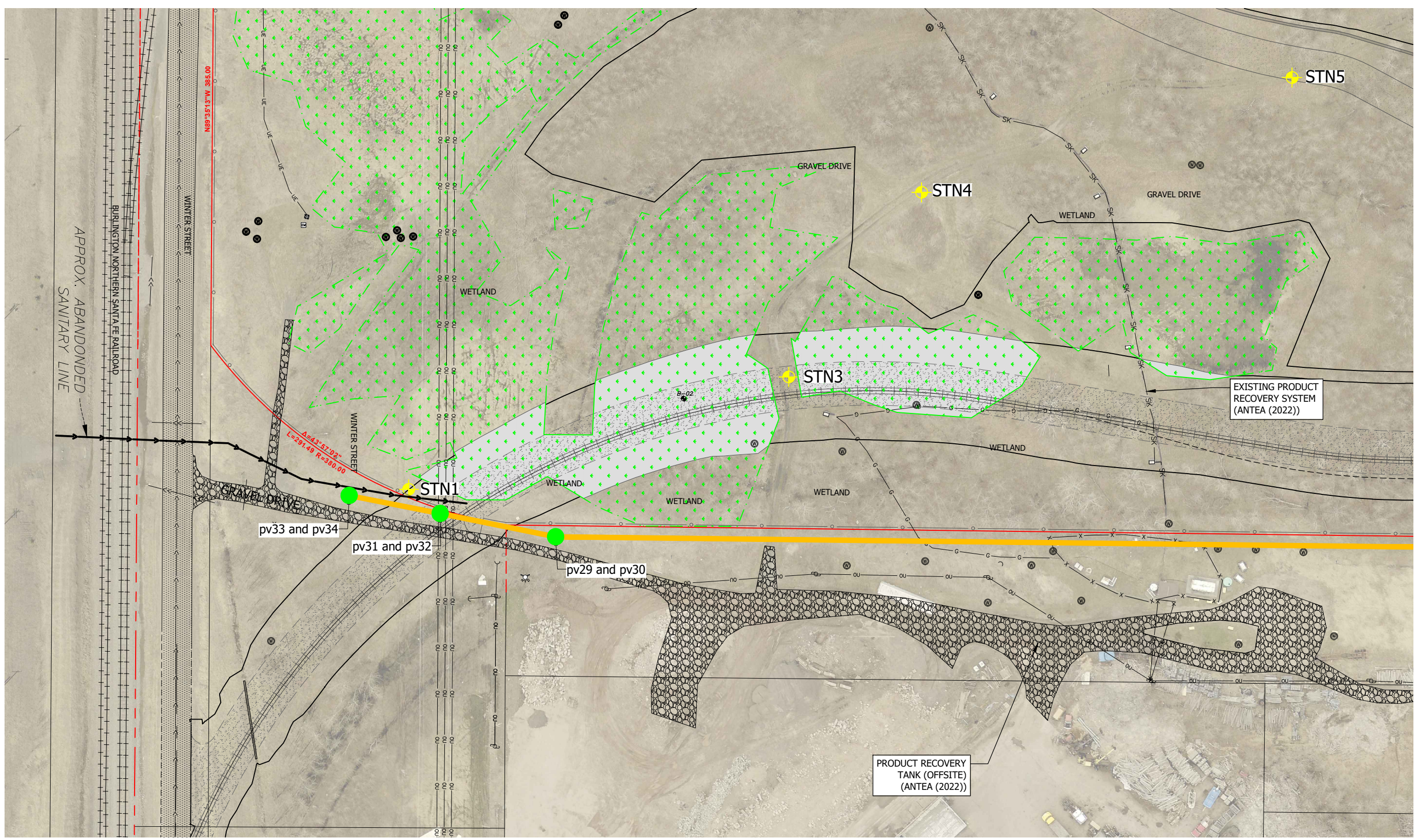

**LEGEND**

- STANTEC (2022a,b) BOREHOLE LOCATIONS
- MAIN SOIL VENT LINE
- PASSIVE SOIL VENT STACK (PV)

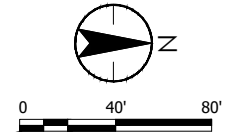
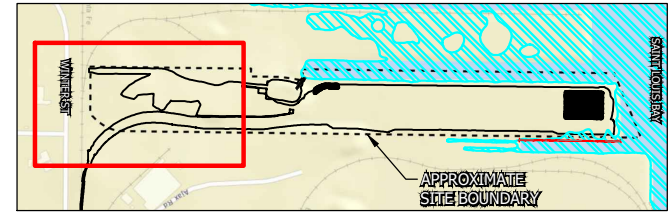

**PASSIVE SOIL VENTING SYSTEM LOCATION MAP**

DATE OF ISSUANCE

NO	REVISION	DATE
3	ADDENDUM	4-18-23
4	ADDENDUM	4-26-23
5	ADDENDUM	4-27-23
6	ADDENDUM	4-28-23
7	ADDENDUM	6-29-23

SURVEY	JIN
DRAWN	AJR
DESIGNED	AJR
CHECKED	AJR
APPROVED	AJR
PROJ. NO.	193707141

SHEET NUMBER  
**FIG. 2**





## **ATTACHMENT A**

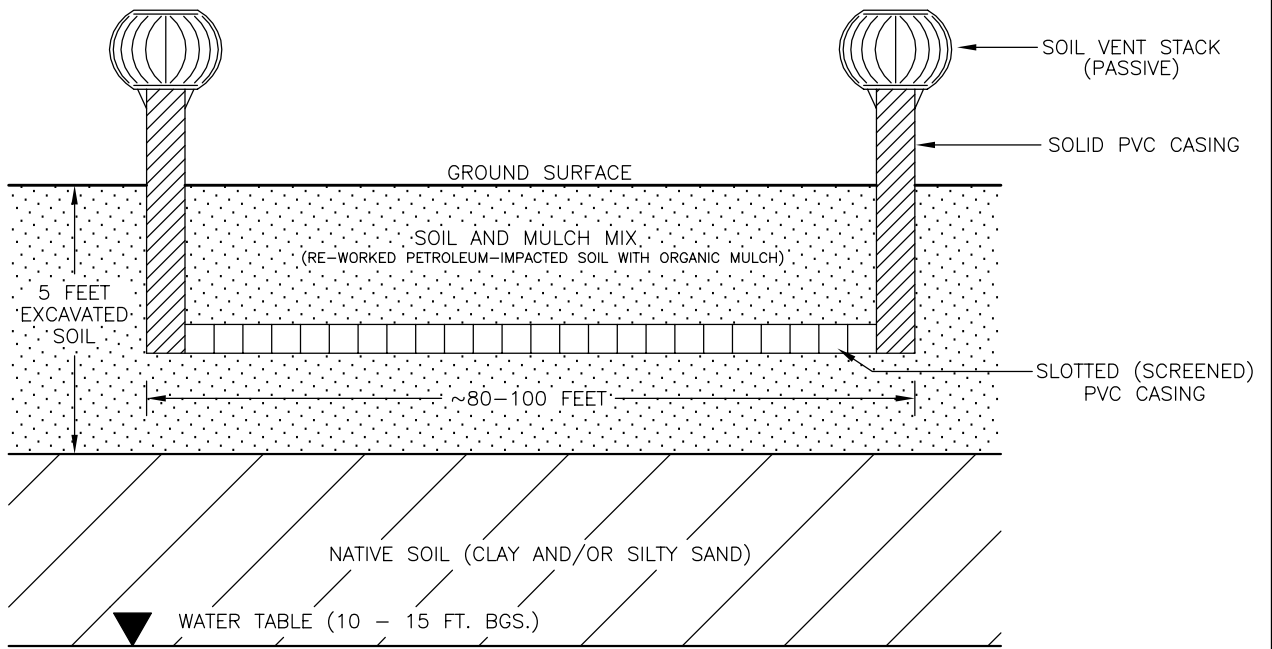

**SIDE VIEW (NORTH TO SOUTH)**

NOT TO SCALE

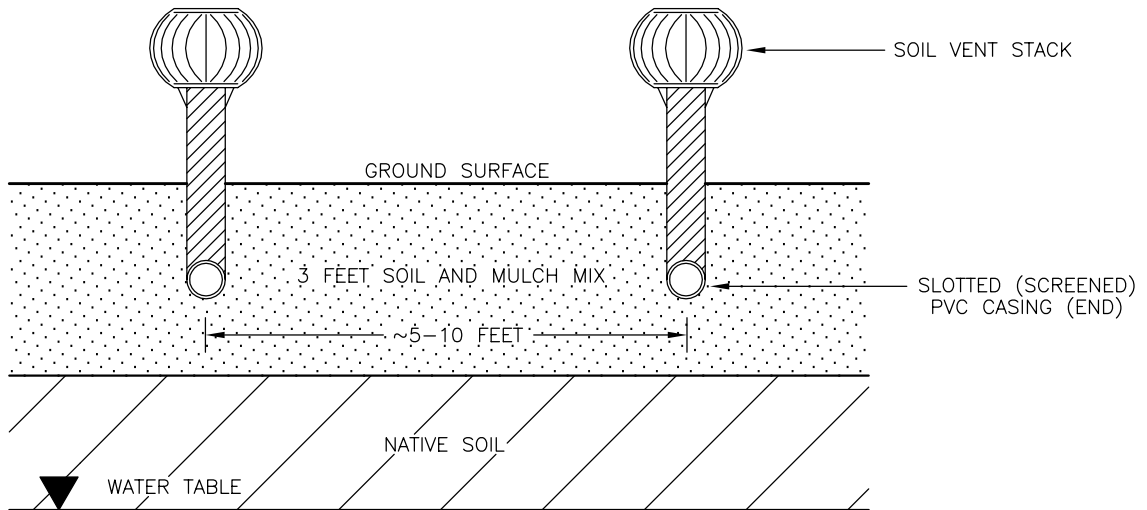

**END VIEW**

NOT TO SCALE

**NOTES:**

DRAWINGS NOT-TO-SCALE.

ALL DEPTHS ARE APPROXIMATE.

ALL DESIGNS ARE CONCEPTUAL.

SOME TRENCH (EXCAVATED) AREAS MAY INCLUDE SINGLE OR MULTIPLE (MORE THAN TWO) VENT LINES.

**FIGURE 7  
PASSIVE SOIL VENTING SYSTEM  
BP PRODUCTS NORTH AMERICA  
SUPERIOR TERMINAL  
SUPERIOR, WISCONSIN**

PROJECT NO. AMG0-06N	PREPARED BY JK	DRAWN BY DD
DATE 1/29/04	REVIEWED BY	FILE NAME JAN04-JK-7



**Delta**  
Environmental  
Consultants, Inc.