

Prepared by:
Emmons & Olivier Resources, Inc.
for the City of Cumberland
in conjunction with the Beaver Dam Lake Management District

CITY OF CUMBERLAND Stormwater Management Plan Update



Cover Image

Norwegian Bay | Beaver Dam Lake
photo by Marty Peters

Mayor

Daniel C. Shoemaker

City Council

Steve Anderson
Foster Bridger
Michael Cifaldi
Tom Goldsmith
Bill Lussier
Doris Laursen
Jim “Butch” O’Dell
James Schullo

City Staff

Jerry Lindfors, Street Department
Kim Rieper, City Clerk/Treasurer
Arlene Frisinger, Deputy Clerk/Treasurer

Consultants

Emmons & Olivier Resources, Inc. (EOR)
Britta Hansen, PLA
Derek Lash, PE
Jay Michels, CPESC
Karli McCawley
Sarah Voje

Special thanks to:

Wisconsin DNR staff

West Central Wisconsin Regional Planning Commission

Barr Engineering

for providing assistance and relevant data for the preparation of this plan

THIS PAGE LEFT BLANK INTENTIONALLY

Table of Contents

1. Introduction	1
2. Water Resource and Land use Summary	3
Land Use.....	5
Soils	7
Hydrology.....	9
3. Current Conditions of Surface Waters	13
Beaver Dam Lake and Bays	13
Surface Water Quality	13
Aquatic Vegetation	14
Fish.....	15
Hay River	17
Collingwood Lake.....	17
Stormwater.....	17
Sediment Samples	17
4. Plan Goals and Identified Needs.....	19
5. Watershed Modeling	21
Runoff Volume Modeling.....	21
Model Development.....	21
Results.....	21
Water Quality Modeling.....	22
Model Development.....	22
Results.....	22
6. Stormwater Management Recommendations.....	25
Priority Subwatersheds	25
Library Lake Restoration	25
Stormwater Improvements	25
Park Development	26
7. Stormwater Best Management Practices	29
8. Ordinance Gap Analysis.....	33
Purpose.....	33
9. Public Outreach, Information & Education Framework	37
Target Audiences.....	39
Objectives and Potential Opportunities	39
Construction Professionals.....	40
Residents.....	40
Occasional Users	41
Policy Makers and Government Staff.....	41
Business Owners.....	42
Natural Resource Partnership Groups	42
Students	42
10. Implementation Plan	45
Introduction	45
Implementation Plan Structure.....	45
Implementation Plan Table	46

Implementation Activity Narratives	47
Site Plan Review Permitting & Enforcement	47
Stormwater Infrastructure Inspection & Maintenance	47
Pollution Prevention for City Properties	48
Aquatic Invasive Species Management	48
Monitoring and Data Assessment	48
Education and Outreach.....	48
Ordinance Development & Revisions.....	51
Storm Sewer Outfall Dredging Policy	52
Riprap at Storm sewer Outlets	52
Pipe Maintenance.....	52
Stormwater Infrastructure Improvements	52
Library Lake Watershed Stormwater Improvements and Park Development	53
Library Lake Restoration and Shoreline Restoration	53
Library Lake Outlet Restoration.....	53
Pollution Prevention Plans for Industrial Sites	53
Collingwood Lake Monitoring	53
Collingwood Lake Stormwater Management Facility Identification and Siting.....	54
Cemetery Bay Watershed Stormwater Management Facility Identification and Siting.....	54
Rabbit Island Bay Watershed Stormwater Management Facility Identification and Siting	54
Norwegian Bay Watershed Stormwater Management Facility Identification and Siting	54
Landlocked Basin Stormwater Management Facility Identification and Siting.....	55
Vermillion River Watershed (Cumberland Municipal Airport) Stormwater Management Facility Identification and Siting	55
Beaver Dam Lake West Watershed Stormwater Management Plan for Future Development.....	55
Implementation Plan Table	57
11. Financing Options	59
Stormwater Utility	59
Special Assessments	59
Area Charges (and Other Fees).....	59
Municipal Bonding.....	60
Grants	60
12. References	63
APPENDIX A. STORMWATER BEST MANAGEMENT PRACTICES	65
Better Site Design (BSD)	65
Amended Soils	65
Native Landscaping	65
Reducing Impervious Surfaces	66
Natural Area Protection	67
Open Space Design	67
Vegetated Buffers.....	68
Structural BMPs	69
Pre-treatment & Filtration practices.....	69
Infiltration, Evaporation and Detention Practices	71
Phosphorus Reduction Practices	81
Programmatic BMPs	82
Municipal Programs & Standards	82

List of Figures

Figure 1. City of Cumberland in the context of drainage areas to Beaver Dam Lake.	4
Figure 2. Existing (2017) Land Use.	5
Figure 3. Future Land Use (from 2017 Comprehensive Plan).	6
Figure 4. Hydrologic soil groups.	8
Figure 5. City of Cumberland drainage areas and waterbodies.	10
Figure 6. Average annual total phosphorus and total suspended solids leaving city subwatersheds normalized by subwatershed area (existing land use).	24
Figure 12. Stormwater Improvement Projects Completed Around Library Lake since 2010	28
Figure 45: Installed silt fence will minimize sediment leaving a site and contaminating surface waters.	32
Figure 13: Impervious cover removal in backyard (https://www.riversmarthomes.org/isr).....	66
Figure 14: Trees and Vegetation Planted in the Landscaped Island of a Cul-de-sac (left) and a Loop Road (right) (Minnesota Pollution Control Agency 2013)	67
Figure 15: Turnaround Options for Residential Streets (adapted from: Schueler 1995).....	67
Figure 16: A conventional subdivision (left - 72 lots) with alternative layouts (center - 72 lots; right - 66 lots) implementing open space design.	68
Figure 17: Shoreline buffer (EOR)	68
Figure 18: Settling Devices	70
Figure 20: Vegetated Filter Strip	71
Figure 21: Bioretention basin diagram	71
Figure 23: Permeable Asphalt	72
Figure 24: Permeable Concrete	73
Figure 25: Permeable Concrete Pavers	73
Figure 26: Concrete Grid	73
Figure 27: Infiltration Basin doubling as recreational space	74
Figure 28: Infiltration Trench (MPCA)	75
Figure 32: Underground infiltration chambers being installed under a parking lot (EOR).....	76
Figure 35: Swale with Native Landscaping	77
Figure 36: Level Spreader (MPCA).....	77
Figure 39: Rain barrel for harvesting roof runoff	78
Figure 40: Green Roof on Amery Regional Hospital (EOR)	79
Figure 42: Stormwater Wetland in Cumberland (EOR).....	80
Figure 43: Installation of Iron-Enhanced Sand Filter in Deerwood, MN (EOR).....	81
Figure 44: Street Sweeping in Residential Neighborhood (EOR)	83

THIS PAGE LEFT BLANK INTENTIONALLY

List of Tables

Table 1. Description of hydrologic soil groups.	7
Table 2. Beaver Dam Lake water quality 2007	14
Table 4. 1993-1994 and 2006-2007 creel survey data by season for major game and panfish species in Beaver Dam Lake. Table credit: Benike and Disrude (2008). ...	16
Table 5. Fall electrofishing catch per effort of gamefish (fish/hour) in Beaver Dam Lake. Table credit: Benike and Disrude (2008).....	16
Table 6. Levels (above 1) of metal in sediment at northeast storm sewer outfall delta to Rabbit Island Bay based on DNR CBSQGs (DNR, 2003).	18
Table 7. Stormwater runoff volume to Cumberland waterbodies from within city limits.	21
Table 8. Total phosphorus and total suspended solids loading to Cumberland waterbodies	23
Table 9 Average annual total phosphorus and total suspended solids leaving city subwatersheds normalized by subwatershed area.	23
Table 11. Library Lake restoration project phases.	25
Table 17. Implementation plan organization: categories and activities.....	46
Table 18. Potential Grant Sources.....	61
Table 13: Environmental factors to consider when integrating stormwater and landscaping.	65
Table 14: Rainwater / Stormwater Uses	86

THIS PAGE LEFT BLANK INTENTIONALLY

1. INTRODUCTION

The City of Cumberland and the Beaver Dam Lake Management District are collaborative managers of their community's shared water resources. Lakes surround the 'Island City' and provide the economic engine of this tight-knit community as well as a cultural foundation for residents and seasonal visitors. In the interest of the health of Beaver Dam Lake and its bays (Cemetery Bay, Norwegian Bay, Rabbit Island Bay and Library Lake), Collingwood Lake, the Hay River and adjacent waterbodies, the city of Cumberland has authorized this update to the Stormwater Management Plan which was originally completed in December of 2010. The past decade has been a very busy time in the history of Cumberland's water resources. Multiple water quality projects were implemented around Library Lake in downtown Cumberland and throughout the city, and more remain in the planning stages. This plan will document the tremendous work to date and chart a path for the next ten years of stormwater management in the City of Cumberland.

Chapter 2 Water Resource and Land Use Summary describes the city's water resources and landscape characteristics: land use, soils and hydrology. *Chapter 3 Current Conditions of Surface Waters* is a thorough compilation of findings on the current condition of surface waters based on studies conducted for lake management work. Surface water characteristics such as water quality, aquatic vegetation and fish populations are summarized. Greater detail is presented in Appendix A. Based on this information, surface water resource goals and needs for this stormwater management plan were developed and are presented in *Chapter 4 Plan Goals and Identified Needs*.

Chapter 5 Watershed Modeling describes runoff and water quality modeling conducted specifically for the identification of target drainage areas for stormwater management within the city of Cumberland. Ultimately, practical stormwater management recommendations are made based on model results and findings from field visits. These recommendations are presented in *Chapter 6 Stormwater Management Recommendations*.

Chapter 7 Stormwater Best Management Practices provides a general description of structural and programmatic stormwater best management practices (BMPs), and a recommended list of programmatic BMPs and programs to implement in Cumberland.

Chapter 8 Ordinance Gap Analysis entails a review of city ordinances for their ability to accommodate and/or facilitate development that contributes to healthy surface waters (practices that reduce impervious surfaces and enhance infiltration, water quality treatment, and volume control).

Chapter 9 Public Outreach, Information & Education Framework provides a framework for public outreach, information and education programming.

Chapter 10 Implementation Plan provides a detailed stormwater management implementation plan including action items, planning-level costs, responsible parties, and a timeline.

Chapter 11 Financing Options provides general description of options the city may consider in order to fund action items of the implementation plan.

References are provided in *Chapter 12*. Appendix A provides more detailed information on structural and programmatic stormwater best management practices.

2. WATER RESOURCE AND LAND USE SUMMARY

The City of Cumberland in Barron County, Wisconsin, is four square miles in size, 14% of which is covered by Beaver Dam Lake and its bays (Cemetery Bay, Norwegian Bay, Rabbit Island Bay and Library Lake) and Collingwood Lake. The city had a population of 2,274 as of 2020 census. Beaver Dam Lake and its watershed extend considerably beyond city boundaries (Figure 1). Beaver Dam Lake itself is 1,112 acres in size, with a maximum depth of 106 feet. It is the deepest lake in Barron County and the sixth deepest lake in the state of Wisconsin.

Beaver Dam Lake and its bays, Collingwood Lake, and the Hay River in the City of Cumberland are recognized as Areas of Special Natural Resource Interest (ASNRI) by the Wisconsin Department of Natural Resources (DNR). Beaver Dam Lake is a popular recreation destination and many people from across the state and beyond vacation there in summer months. It has six public boat landings, a heavily used swimming beach with a fishing pier. Fishing includes Panfish, Largemouth Bass, Smallmouth Bass, Northern Pike, Trout and Walleye.

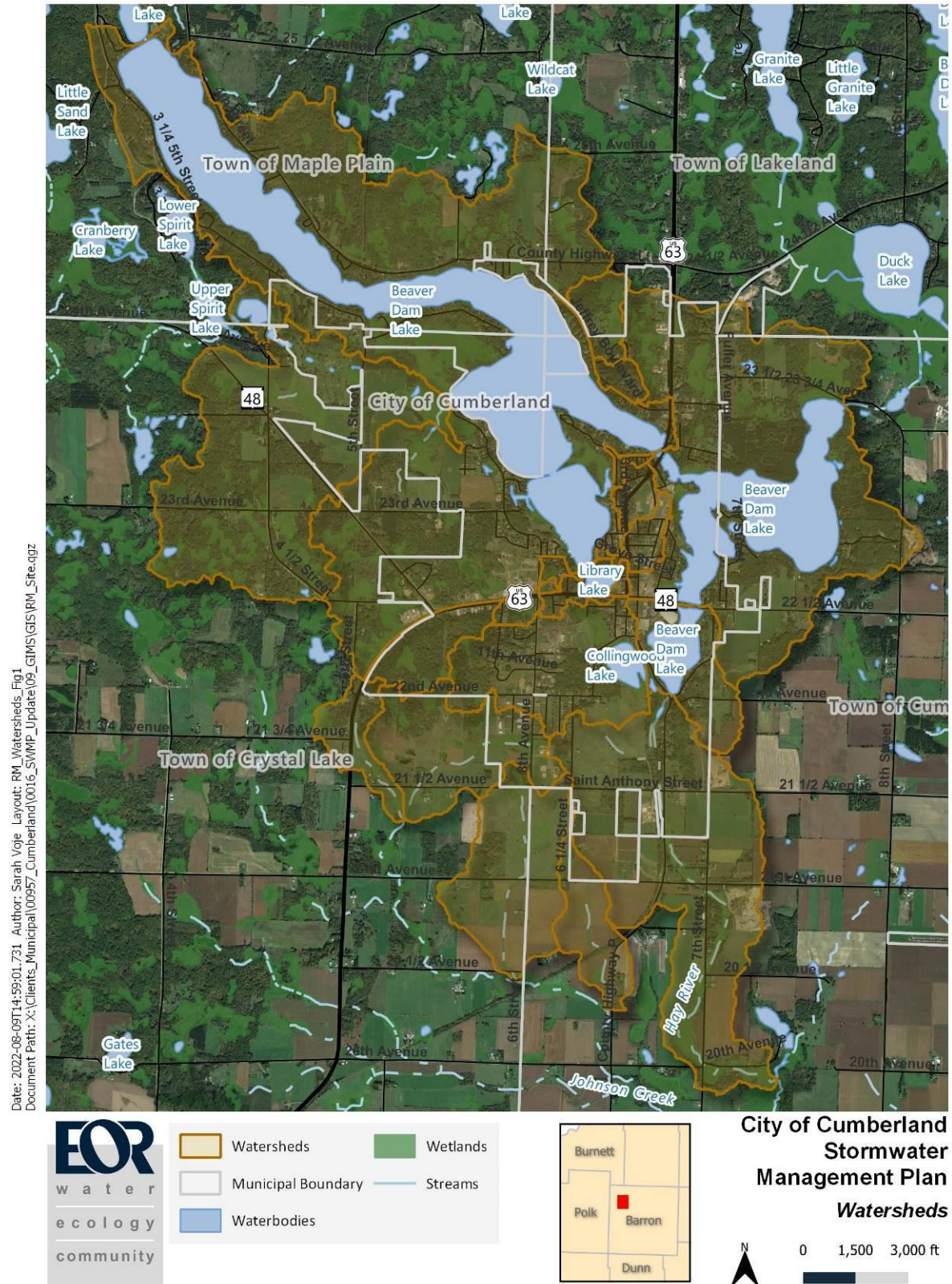

Figure 1. City of Cumberland in the context of drainage areas to Beaver Dam Lake.

Land Use

Existing (2017) and future land use in the city are based on the City of Cumberland Comprehensive Plan (Figure 2 and Figure 3). A portion of land within the city is considered vacant. Landcover types of vacant land include forest, primarily, and agriculture.

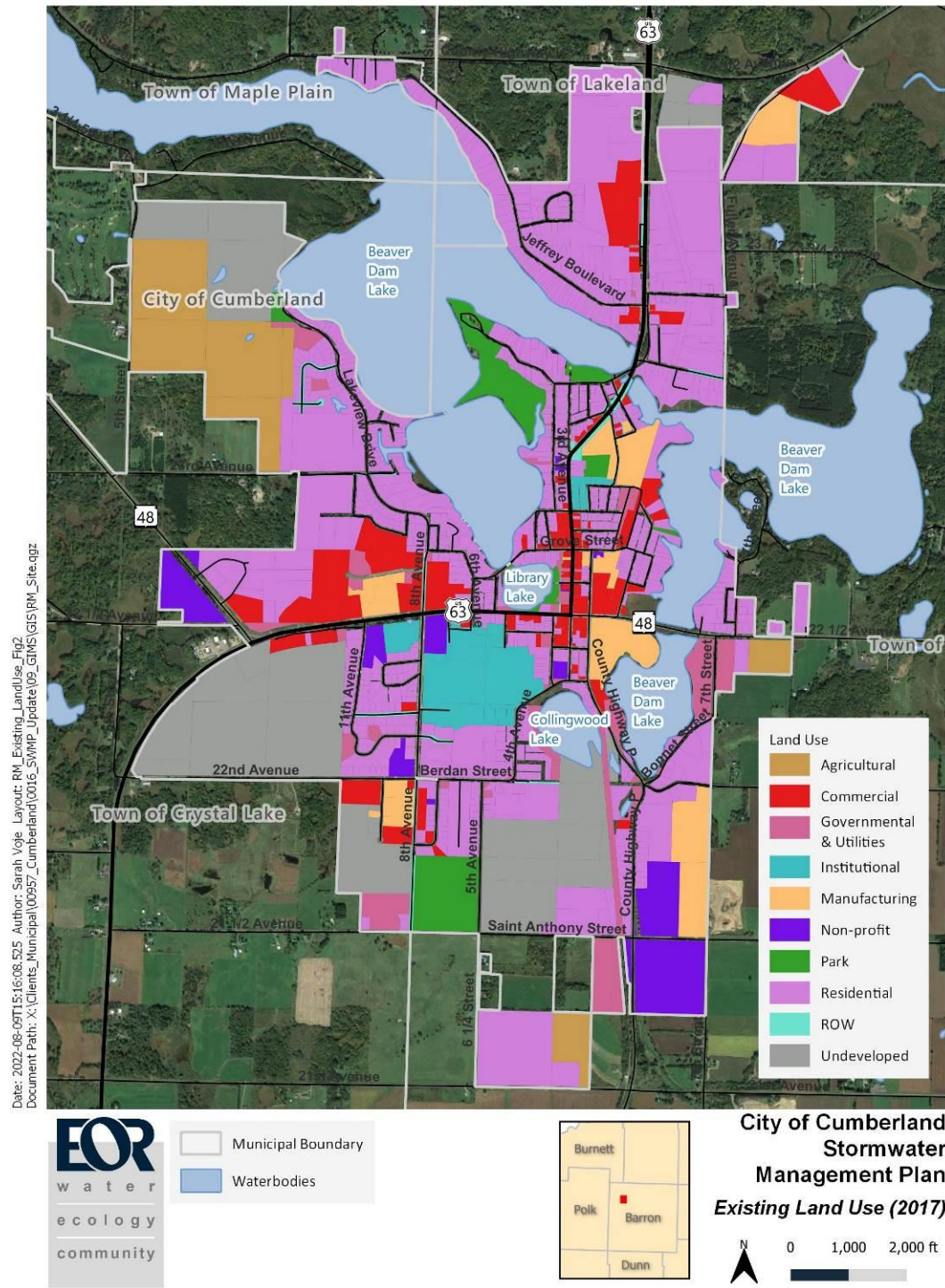

Figure 2. Existing (2017) Land Use.

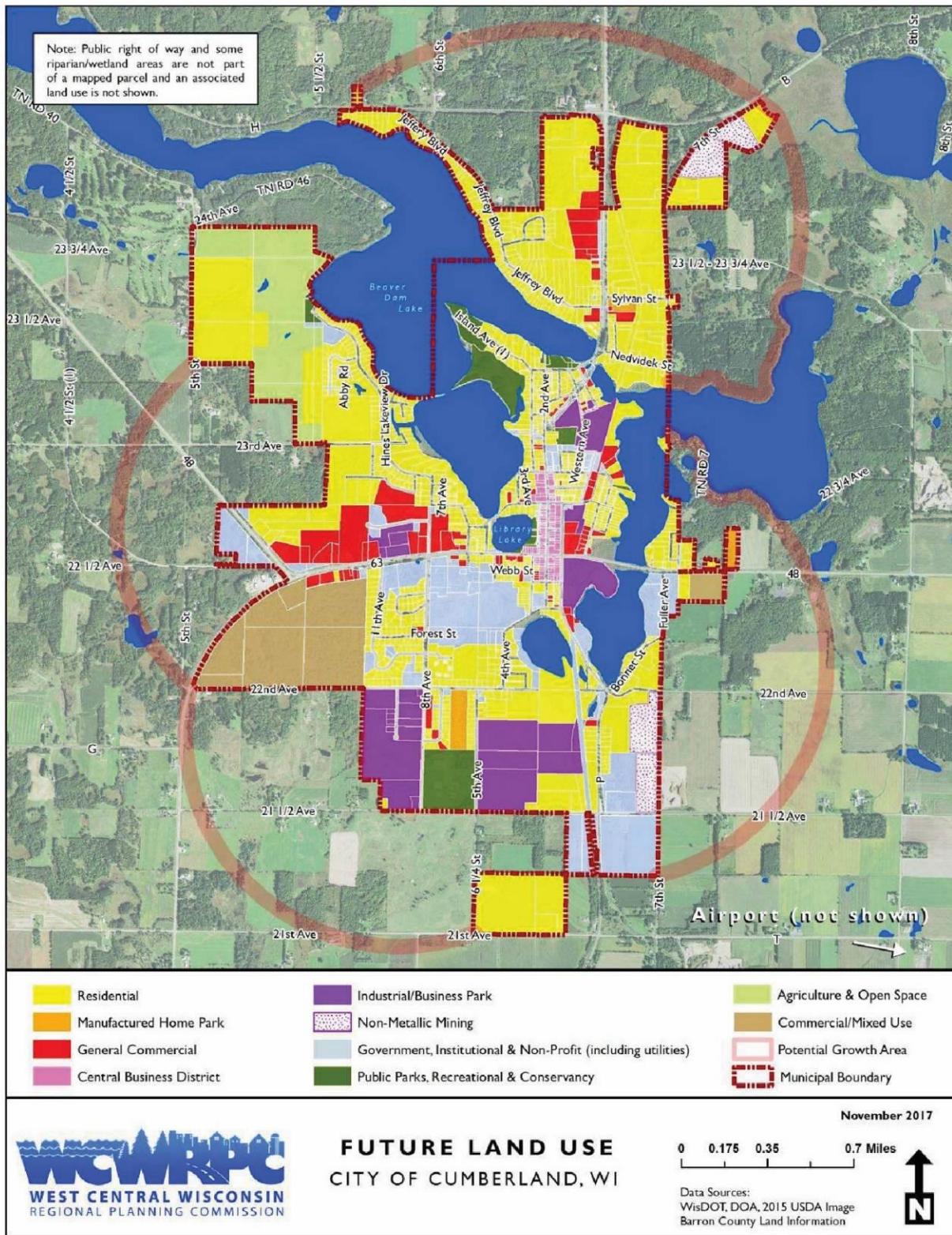

Figure 3. Future Land Use (from 2017 Comprehensive Plan).

Soils

A map identifying the soils of the city is included as Figure 4. As this map illustrates, the soils are classified based upon the hydrologic characteristics of the soils. Soil hydrologic groups are used to estimate the amount of runoff generated for a given rainfall event. There are four hydrologic soil groups (HSG): A, B, C and D. The amount of runoff expected from the soil is lowest for A soils. These soils have a high sand and/or gravel content that allows water to move rapidly down into the soil instead of flowing off the soil. Runoff is highest for D soils. HSG D soils have a large clay content that prohibits the movement of water through the soil. Ultimately however, vegetation, organic/mineral or physical composition and slope all contribute to the runoff potential of a soil. Table 1 presents a description for each of the HSGs. Soils classified as, for example, A/D are A soils that behave like D soils.

Table 1. Description of hydrologic soil groups.

Hydrologic Soil Group	Description
A	Soils having high infiltration rates when thoroughly wet (low runoff potential). Deep, well drained to excessively drained sand or gravelly sand.
B	Soils having a moderate infiltration rate when thoroughly wet. Moderately deep or deep, moderately well drained or well drained with moderate to moderately coarse texture.
C	Soils having a slow infiltration rate when thoroughly wet: soils have a layer that impedes the downward movement of water or soils of moderately fine texture or fine texture.
D	Soils having very slow rates of infiltration when thoroughly wet (high runoff potential): soils consist of clays with high shrink-swell potential; soils have a high permanent water table; soils that have a claypan or clay layer at or near the surface and soils that are shallow over nearly impervious material.

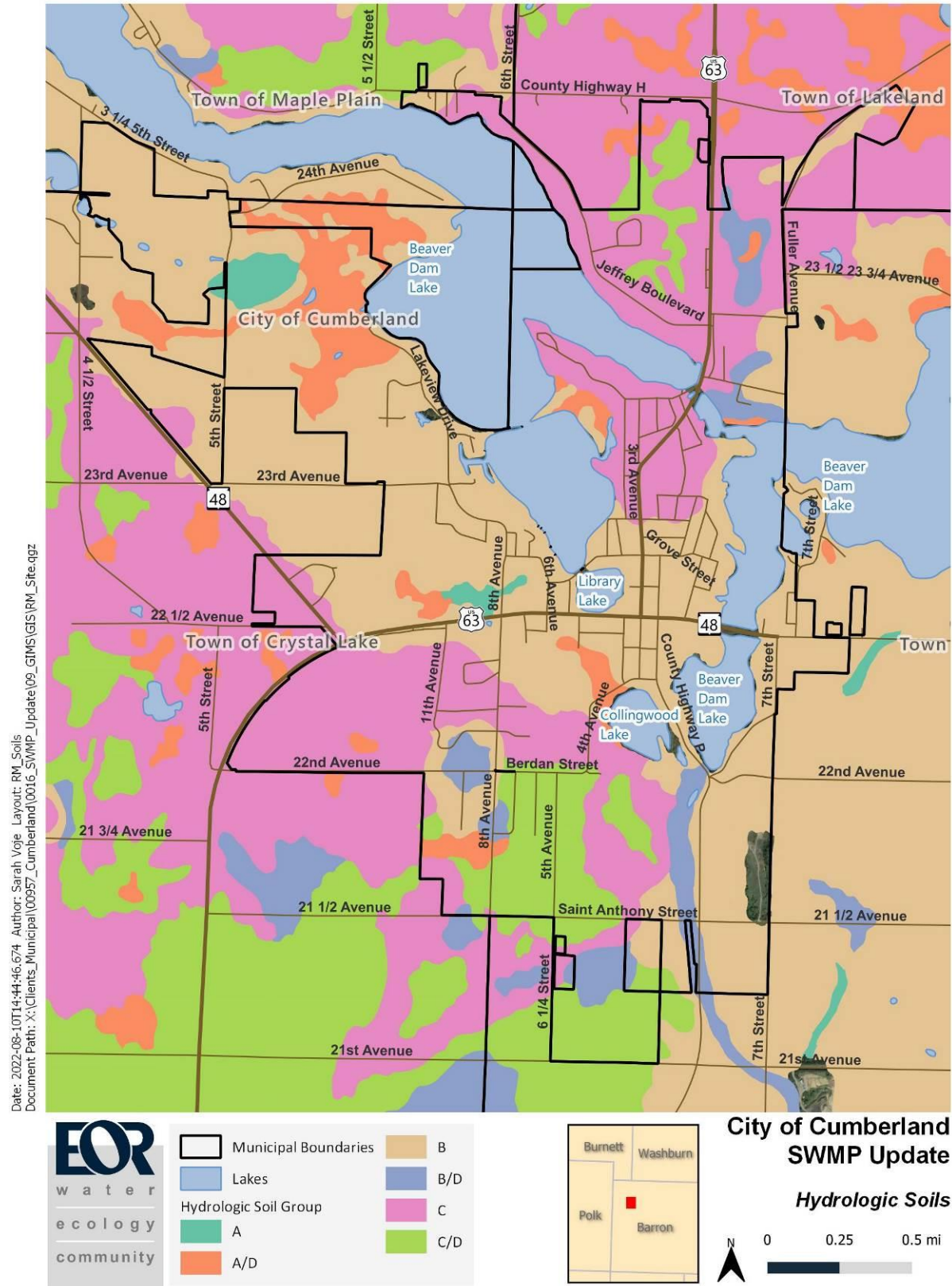

Figure 4. Hydrologic soil groups.

Hydrology

Waterbodies within the city of Cumberland receive stormwater runoff from areas outside of city boundaries. Figure 5 shows more detailed hydrology within city boundaries; drainage patterns are illustrated with black arrows. Hay River is the historic outlet of Library Lake. However, today, Library Lake is only connected to the north to Rabbit Island Bay of Beaver Dam Lake. Beaver Dam Lake flows clockwise and discharges at the southeastern tip to the Hay River. Cumberland Municipal Airport (110 acres in size) is southeast of the map extents (not shown in Figure 5) and discharges to the Vermillion River. The Hay and Vermillion Rivers ultimately discharge to the Red Cedar River.

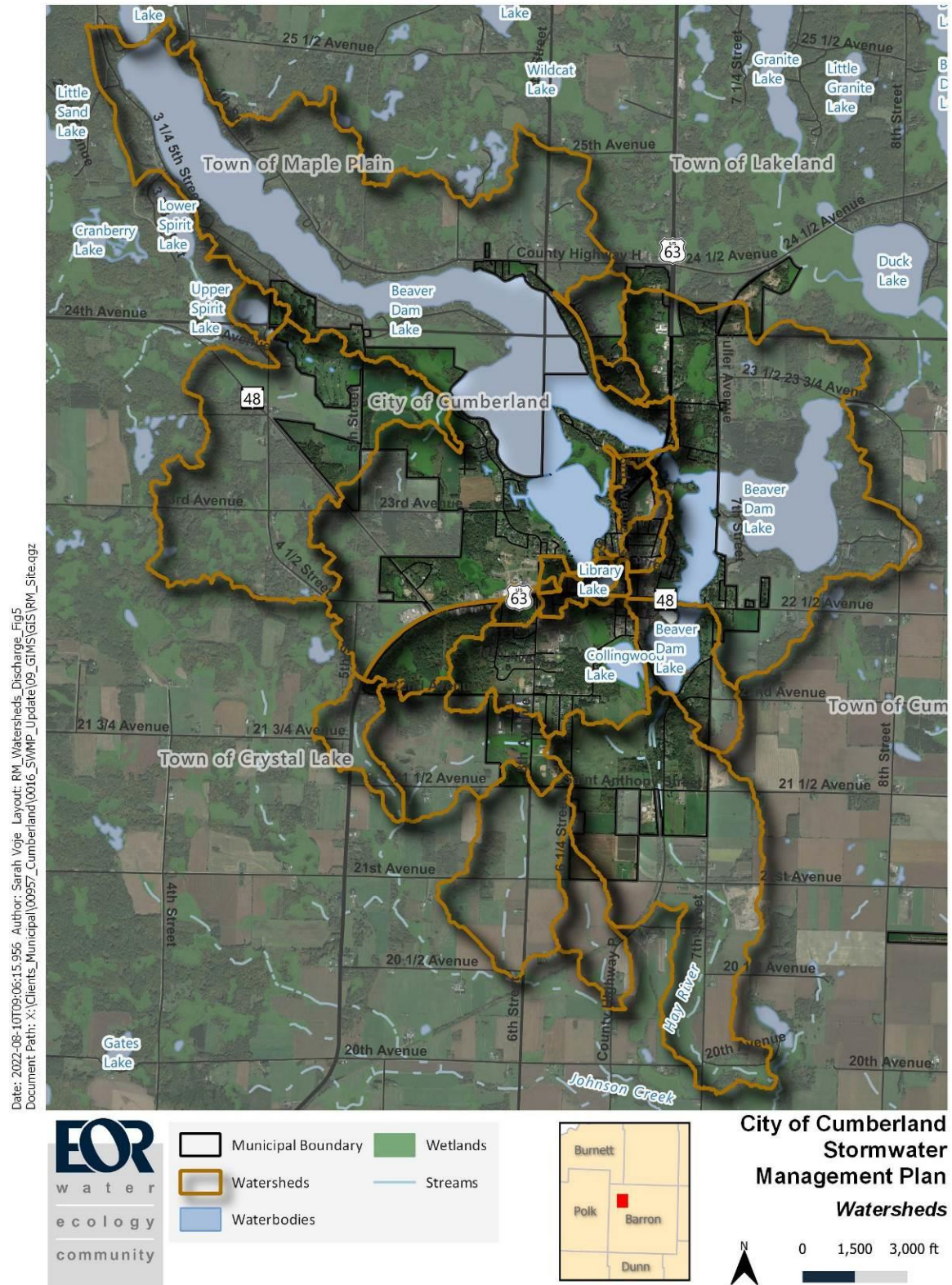
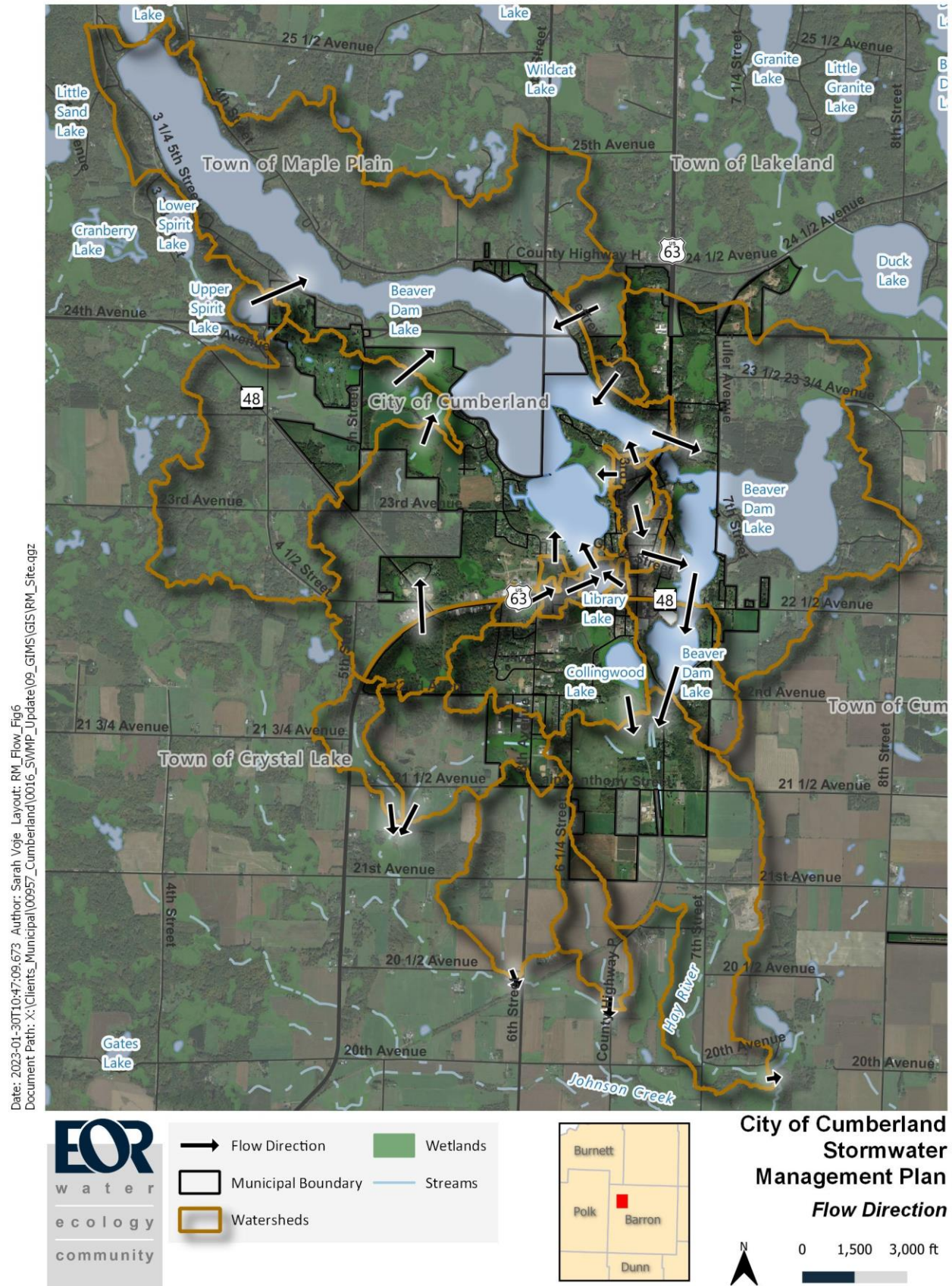

Figure 5. City of Cumberland drainage areas and waterbodies.
 Not shown: Cumberland Municipal Airport (110 acres) southeast of map extents; drains to the Vermillion River.



THIS PAGE LEFT BLANK INTENTIONALLY

3. CURRENT CONDITIONS OF SURFACE WATERS

Beaver Dam Lake and Bays

Surface Water Quality

Surface water quality can be defined in terms of the trophic status: hypereutrophic, eutrophic, mesotrophic and oligotrophic. Eutrophic waters have high primary productivity as a result of high nutrient content and are often identifiable by algal blooms resulting in poor water quality and poor water clarity. Hypereutrophic waters are in an extreme state of eutrophication. Oligotrophic waters have low concentrations of nutrients and algae resulting in high water clarity. Mesotrophic waters are in a state between oligotrophic and eutrophic. In order to define the trophic status, water quality measurements are taken, in particular, secchi depth (transparency), nutrients (in particular, phosphorus) and chlorophyll (an indicator of primary productivity).

The Beaver Dam Lake Management District (District) commissioned the *2007 Beaver Dam Lake Water Quality Study* that was completed in April 2008 (Barr, 2008). The report is the most recent compilation of the current water quality conditions of Beaver Dam Lake and the overall trends in comparison to years past. Beaver Dam Lake surface water quality reported in this study are summarized in Table 2. Appendix A includes a detailed compilation of the findings from this study including monitoring locations and graphs of the data.

Table 2. Beaver Dam Lake water quality 2007

Waterbody	2007 Water Quality	Water Quality Trends
Beaver Dam Lake West	Excellent – varying from oligotrophic to borderline oligotrophic/mesotrophic	Overall water quality consistent since 1992; water transparency consistently mesotrophic since 1975
Beaver Dam Lake East – Cemetery Bay	Poor – varying from eutrophic to hypereutrophic	Overall water quality has deteriorated since 1994 and water transparency declined since 1994; these are attributed to increased internal phosphorus loading during dry years
Beaver Dam Lake East – Norwegian Bay	Poor – varying from oligotrophic to hypereutrophic	Overall water quality has deteriorated since 1994 and water transparency declined since 1994; these are attributed to increased internal phosphorus loading during dry years and following treatment and decay of Eurasian water milfoil
Beaver Dam Lake West – Rabbit Island Bay and Library Lake	Reasonably good – varying from mesotrophic to eutrophic	Overall water quality generally declining since 1994; water transparency consistently oligotrophic or mesotrophic since 1992.

Source: (Barr, 2008)

Aquatic Vegetation

The Beaver Dam Lake Management District commissioned the *2008 Beaver Dam Lake Report and Amended Aquatic Plant Management Plan* which was completed in February 2009 (Barr, 2009). This report was updated in 2021 as *The Beaver Dam Lake Aquatic Plant Management Plan*. This report outlines the history of infestation and treatment of invasive aquatic plants in Beaver Dam Lake.

After being accidentally introduced into Beaver Dam Lake in 1991, Eurasian water milfoil (EWM) spread to cover 73% of the littoral area of the lake by 1999. Coordinated herbicide treatment from 2000-2020 successfully reduced the area of EWM coverage to just over 12% of littoral area. Continued herbicide treatment is taking place in order to meet the goal of reducing EWM coverage to 7% or less of littoral area.

In addition to EWM, curly-leaf pondweed (CLP) poses a threat to the health of native plant communities in and around Beaver Dam Lake. Management is taking place in order to prevent the spread of CLP.

Fish

Beaver Dam Lake has a diverse fishery. Fish include walleye, northern pike, largemouth bass, smallmouth bass, bluegill, black crappie, pumpkinseed, green sunfish, yellow perch, rock bass, common carp, white sucker, cisco, rainbow smelt and bullheads (Benike and Disrude, 2008). It is inconclusive whether Beaver Dam Lake is within the native range of walleye; however, headwater areas of the Red Cedar River (to which Beaver Dam Lake is tributary), is considered within the native range. Walleye stocking in Beaver Dam Lake has occurred sporadically since 1933 and, since 1978, on a regular basis. Trout stocking occurred for several years in the early 1980s and again since 2006 as a biological control to predate rainbow smelt. (Benike and Disrude, 2008).

In Table 3, 1993-1994 creel survey data on Beaver Dam Lake is compared to 2006-2007 survey data for major game and panfish species. In Table 4, fall electrofishing catch per effort of gamefish (fish/hour) is provided for survey years of 1970 through 2006. Angling effort for walleye in 2006-2007 was 7.9% of the total directed effort including open water and ice seasons (Table 3). The size distribution in 2006 was excellent (mean length 21.0 inches and 4% larger than 28 inches). In 1993, mean length of walleye was 18.9 inches with only 1% larger than 28 inches (Benike and Disrude, 2008). However, adult walleye abundance was similar from 1993 and 2006, and it was 50 to 75% lower than in 1979 (Benike and Disrude, 2008). In 2006, largemouth bass catch per unit effort was 22 fish/hour (Table 4). Average catch per unit effort was 7 fish/hour prior to the 2006 survey. In fact, largemouth bass relative abundance is at the highest levels in 25 years. Relative abundance of smallmouth bass has also been increasing (12 fish/hour in 2006, see Table 4), but was lower than largemouth bass and northern pike. *Beaver Dam Lake is one of a handful of lakes in Barron County that has a fishable population of smallmouth bass and that should be maintained and even possibly enhanced* (Benike and Disrude, 2008). The northern pike and panfishery have remained stable.

Table 3. 1993-1994 and 2006-2007 creel survey data by season for major game and panfish species in Beaver Dam Lake. Table credit: Benike and Disrude (2008).

Species	Season	Year	Directed Effort Percent	Catch rate (fish/hr)	Harvest rate (fish/hr)	Mean length harvested (in)
Walleye	Open Water	1993	9.6	0.0339	0.0110	18.8
		2006	9.0	0.0231	0.0111	17.2
	Ice	1994	13.1	0.0000	0.0000	N/A
		2006	1.8	0.0000	0.0000	N/A
Northern Pike	Open Water	1993	16.3	0.4054	0.0462	19.9
		2006	13.2	0.3834	0.1250	20.0
	Ice	1994	57.0	0.3002	0.1466	21.4
		2006	57.4	0.3296	0.1200	20.3
Smallmouth bass	Open Water	1993	11.9	0.2082	0.0137	15.5
		2006	25.1	0.3664	0.0074	16.4
	Ice	1994	5.8	0.0000	0.0000	N/A
		2006	0	0.0000	0.0000	N/A
Largemouth bass	Open Water	1993	21.4	0.2095	0.0051	15.6
		2006	24.2	0.5961	0.0061	15.6
	Ice	1994	3.2	0.0599	0.0599	16.4
		2006	29.4	0.0568	0.0378	15.6
Bluegill	Open Water	1993	21.3	2.8061	1.2788	6.9
		2006	20.6	3.9616	1.0932	6.8
	Ice	1994	10.8	3.5205	1.6760	6.7
		2006	3.8	1.3013	0.4042	6.5
Black crappie	Open Water	1993	18.1	0.8566	0.5088	9.2
		2006	5.5	0.6012	0.3862	9.2
	Ice	1994	8.8	0.0147	0.0147	8.8
		2006	5.6	0.0779	0.0564	9.5
Yellow perch	Open Water	1993	0.0	*	*	9.4
		2006	0.0	*	*	*
	Ice	1994	1.3	0.1523	0.0000	7.2
		2006	1.9	0.3402	0.0000	*

* not available

Table 4. Fall electrofishing catch per effort of gamefish (fish/hour) in Beaver Dam Lake. Table credit: Benike and Disrude (2008).

Date	Walleye	Northern Pike	Largemouth Bass	Smallmouth Bass
1970	54	7	9	0
1979	12	16	3	1
1984	67	26	14	4
1988	13	7	6	3
1989	12	7	6	1
1993	6	27	4	6
2006	N/A	22	22	12

Hay River

Hay River is the historic outlet of Library Lake, discharging through Collingwood Lake and south out of Cumberland ultimately discharging to the Red Cedar River just north of Menomonie, WI. Today, Library Lake and Hay River are disconnected, but Beaver Dam Lake still discharges to the south to Hay River. Hay River drains much of the high school and surrounding properties (Figure 5) in Cumberland and runs through a wetland complex that discharges to Collingwood Lake. Hay River has not undergone water quality monitoring or aquatic plant surveys.

Collingwood Lake

Collingwood Lake is 20 acres in size and discharges via Hay River at the south end of the lake. Like Hay River, it has not undergone water quality monitoring or aquatic plant surveys.

Stormwater

Sediment Samples

Three sediment samples were collected in October 2009 from a storm sewer outfall delta downstream of primarily residential and some commercial land uses at the northeast side of Rabbit Island Bay. Texture, inorganics, metals, organics and oil and grease were analyzed. The DNR has developed guidelines for sediment quality for metals, polycyclic aromatic hydrocarbons (PAHs), polychlorinated biphenyls (PCBs) and additional assorted contaminants based on effects-based (i.e. empirical) sediment quality guidelines for commonly found, in place contaminants (DNR, 2003). The consensus-based sediment quality guidelines (CBSQGs) are based on effects to benthic macroinvertebrate species. Where noncarcinogenic or nonbioaccumulative organic chemicals are involved, the guidelines should be protective of human health and wildlife concerns. Where bioaccumulative compounds (e.g. PCBs and methyl mercury) are involved, human health or wildlife-based guidelines could result in more restrictive sediment concentrations. At the threshold effect concentration (TEC), toxicity to benthic-dwelling organisms is predicted to be unlikely. At the probable effect concentration (PEC), toxicity is probable. In between is the midpoint effect concentration (MEC). Levels of concern are designated based on the respective effect concentrations (Level 1 – less than or equal to the TEC; Level 2 – greater than the TEC but less than or equal to the MEC; Level 3 – greater than the MEC but less than or equal to the PEC; Level 4 – greater than then PEC).

None of the inorganic constituents analyzed have corresponding CBSQGs. Most of the organic constituents analyzed have corresponding CBSQGs, but none of the organic constituents at any of the three sites resulted in data above the minimum detection limit of the analytical method employed. However, a few metals did appear in the sediment at levels above the TEC and, in some cases, above the MEC or PEC (see Table 5).

Table 5. Levels (above 1) of metal in sediment at northeast storm sewer outfall delta to Rabbit Island Bay based on DNR CBSQGs (DNR, 2003).

Metal	No. of Sites at Concern Level 2	No. of Sites at Concern Level 3	No. of Sites at Concern Level 4
Arsenic			1
Cadmium	3		
Copper	1		
Lead	1	1	1
Zinc	3		

Soil texture at all sites is a medium-fine sand with anywhere from 7% to 13% fines. The high sand component could be the result of sand application for winter road and parking lot maintenance. Typically, when sediment is 93 percent or more sand, sediment is unlikely to be contaminated (MPCA, 2009).

Three additional constituents (barium, selenium and cyanide) have no DNR CBSQGs. Instead, soil reference values (SRVs) from the Minnesota Pollution Control Agency (2009) were used to evaluate the significance of these constituents. Similar to CBSQGs, SRVs are soil contaminant-specific concentration levels indicating based on predicted risk to human health. Neither of these additional constituents exceeded SRVs. Copper, arsenic and PAHs are known to be good indicators of stormwater pollution. Note that no PAHs were tested in the soils analysis. Copper levels are below the lowest SRV, but arsenic at site C exceeded the Level 2 SRV.

Regarding nutrient levels in sediments, the DNR says *Elevated levels of nutrients can lead to eutrophication of water bodies and production and deposition of plant materials in sediments that deplete oxygen levels in the water body when they decompose. Addition and decomposition of natural organic matter and anthropogenic-added organic matter in sediments can lead to production of hydrogen sulfide and ammonia levels that may be detrimental to benthic organisms* (DNR, 2003). Nutrients including total phosphorus, total Kjeldahl as nitrogen and ammonia, were found in the sediment samples at measurable levels. However, the data is inconclusive regarding source, fate and transport of the nutrients.

Recent sediment sampling in Library Lake and the Wickre Harbor area on the west side of Rabbit Island Bay found no elements that exceeded standards.

4. PLAN GOALS AND IDENTIFIED NEEDS

The following goals emphasize protection of Beaver Dam Lake, Library Lake, Collingwood Lake, Norwegian Bay, and Hay River while covering all land within the city boundaries.

GOAL 1 - Reduce stormwater runoff volume, peak flows, and flooding

1.1	Detain (and retain as technically feasible) up to the 1-inch, 24-hour storm event to reduce erosion, sediment transport and runoff temperature and to remove the first flush of stormwater pollutants.
1.2	Utilize stormwater management practices that emulate native hydrology including stormwater retention, infiltration, and peak runoff reduction.
1.3	Protect US Highway 63 from flood damage.
1.4	Enhance highway safety by avoiding flooding hazards.

GOAL 2 - Treat stormwater runoff prior to discharge to city of Cumberland waterbodies to reduce pollutant loading

2.1	Implement structural stormwater best management practices in priority watersheds.
2.2	Implement programmatic best management practices.
2.3	Restore trophic status of Beaver Dam Lake West including Rabbit Island Bay and Library Lake from eutrophic to mesotrophic.
2.4	Restore trophic status of Beaver Dam Lake East including Cemetery Bay and Norwegian Bay from hypereutrophic to mesotrophic.
2.5	Continue on-going total phosphorus, chlorophyll a and Secchi depth monitoring.
2.6	Expand monitoring to Collingwood Lake and Hay River.
2.7	Conduct sediment sampling at major storm sewer outfalls to prioritize dredging.

GOAL 3 - Protect and improve native aquatic and shoreland habitats

3.1	Protect native shoreline habitat from erosion, scouring and sediment deposition at storm sewer outfalls.
3.2	Through water quality improvements, enhance the Beaver Dam Lake fishery as it has a diverse fishery and is only one of a handful of lakes in Barron County that has a fishable population of smallmouth bass.
3.3	Continue on-going aquatic plant surveys.
3.4	Expand aquatic plant surveys to Collingwood Lake and Hay River.

GOAL 4 – Promote Cumberland’s status as a recreation destination by protecting the waters of Beaver Dam Lake

4.1	Protect water quality using programmatic and structural best management practices and continued monitoring.
4.2	Improve the connection between Library Lake and downtown Cumberland by adding lake access points, park space, and trails.
4.3	Improve public access to Beaver Dam Lake and Library Lake through the implementation of active and passive recreation amenities.
4.4	Perform strategic dredging operations to remove sediment build-up from storm sewer outfalls in Library Lake and Beaver Dam Lake.

5. WATERSHED MODELING

Runoff Volume Modeling

Model Development

Runoff quantity modeling was conducted for the City of Cumberland. For ease of review, rainfall-runoff and hydraulic routing were analyzed in HydroCAD which uses the Soil Conservation Service (SCS) TR-20 runoff hydrograph and curve number (CN) procedures, and TR-55 Time of Concentration (Tc) calculations. Due to the high level of impervious surfaces, a time of concentration value of 6 minutes was used. NOAA Atlas 14 rainfall depths and NRCS, 24-hour, MSE3 rainfall distribution were used in the analysis.

Watershed areas were generated using stormwater reports for BMPs installed throughout the City of Cumberland along with topography and storm sewer data. Land Use and Runoff Curve Number layers were generated by combining the following sources:

- For impervious surfaces (streets, parking lots, rooftops), EOR had previously delineated these areas within the city. The layer was updated where needed, and all areas contained in this layer were modeled as impervious surfaces.
- For watershed areas outside of the EOR impervious layer, the QGIS tool "Curve Number Generator" was used to create a composite Curve Number for each subwatershed based on the 2019 National Land Cover Data Set, the current NRCS SSURGO soils layer, and standard look-up tables for Curve Numbers based on land cover and soil type.

Results

The drainage areas within Cumberland were divided into 38 subwatersheds for assessment purposes. Those subwatersheds are identified in Figure 5 on page 10. Table 6 summarizes the results of the runoff volume modeling for current land use conditions for the storm events identified with active BMPs implemented with development

Table 6. Stormwater runoff volume to Cumberland waterbodies from within city limits.

Watershed	Drainage Area [acres]	Half-Inch Runoff (0.5-in, 24-hr rain) [acre-feet]	2-year Runoff (2.7-in, 24-hr rain) [acre-feet]	100-year Runoff (5.8-in, 24-hr rain) [acre-feet]
*Library Lake	39.48	0.855	6.762	17.317
*Collingwood Lake	406.75	2.873	44.999	145.935
*Hay River	1,754.4	1.929	160.048	589.232
Outlet Lake	189.2	3.028	25.252	72.405
*Beaver Dam Lake	3,873.5	42.861	432.468	1,363.895
*Lower Beaver Dam Lake	1,357.8	15.448	168.982	511.961
*14 th and Carlone	114.1	0.352	8.455	33.162
Total	7,735.29	67.345	850.074	2,741.711

* Watershed has distributed BMPs within the watershed, so a total watershed area was used to calculate runoff volume.

Water Quality Modeling

Model Development

Water quality was analyzed using WinSLAMM 10.4.1 for the Minneapolis 1959 regulatory annual average rainfall period, to evaluate total suspended solids (TSS) and total phosphorous (TP) reduction compared to no controls. The WinSLAMM water quality modeling effort was undertaken for two primary reasons:

- 1) Develop a city-wide model for general use and anticipated future stormwater management efforts.
- 1) Identify priority subwatersheds where improved stormwater management would most benefit Cumberland waterbodies.

The land use types, watershed areas, and BMPs from the HydroCAD model were used to create the WinSLAMM model. Drainage areas were delineated based on topography and storm sewer data. The driving input parameters required in WinSLAMM are watershed (land use type), devices (e.g., ponds and lakes), and pollutant characteristics [based on the United States Environmental Protection Agency's Nationwide Urban Runoff Program studies and median sites (USEPA, 1986; Athayede et al., 1983)].

Results

The pollutant loadings contributed by 38 subwatershed areas discharging to Cumberland waterbodies are summarized in Table 7 for current land use conditions. Average annual loading on a per acre basis can be summarized by subwatershed and grouped based on loading rates. Four tiers have been identified: Tier 1 Subwatersheds have the highest loading rates and Tier 4 Subwatersheds have the lowest loading rates. Subwatersheds have been labeled and numbered based on the major drainage area they are in.

Figure 6 illustrates the total phosphorus (TP) and total suspended solids (TSS) loading for each subwatershed under current land use conditions for the city of Cumberland; Table 8 summarizes the resulting tiers.

Table 7. Total phosphorus and total suspended solids loading to Cumberland waterbodies

Waterbody [rank of TP + TSS loading (lb/yr/ac drainage area): 1=highest 6=lowest]	Drainage Area (acres)	Total Phosphorus Loading Rate (lbs/yr/ac drainage area)	Total Suspended Solids Loading Rate (lbs/yr/ac drainage area)
Hay River [3]	1,754.44	0.29	45.18
Collingwood Lake [6]	406.75	0.66	153.65
Library Lake [1]	39.48	0.05	11.72
Beaver Dam Lake [5]	4,027.26	0.28	57.87
Lower Beaver Dam Lake [4]	5,385.09	0.18	47.72
Outlet Lake [2]	5,574.32	0.17	47.35

Table 8. Average annual total phosphorus and total suspended solids leaving city subwatersheds normalized by subwatershed area.

Tier 1	Tier 2	Tier 3	Tier 4
Lake Street	24 ¾ Avenue	Kwik Trip	6 ½ Street
School Pond	14 th and Carlone	NW Library Lake	East Spirit Lake
2 nd Ave & Moser Field	Collingwood Lake	Beaver Dam Lake	6 th Street
3 rd Avenue	NE Library Lake	Hay River	Library Lake
Arcade Avenue	Goldsmith	21 ½ Avenue	Lower Beaver Dam
SW Library Lake	Golf Course	Cifaldi Lundquist	SE Library Lake
			Outlet Lake

Tier 1 indicates subwatersheds with the highest levels of phosphorus and TSS export. Tier 4 subwatersheds have the lowest levels.

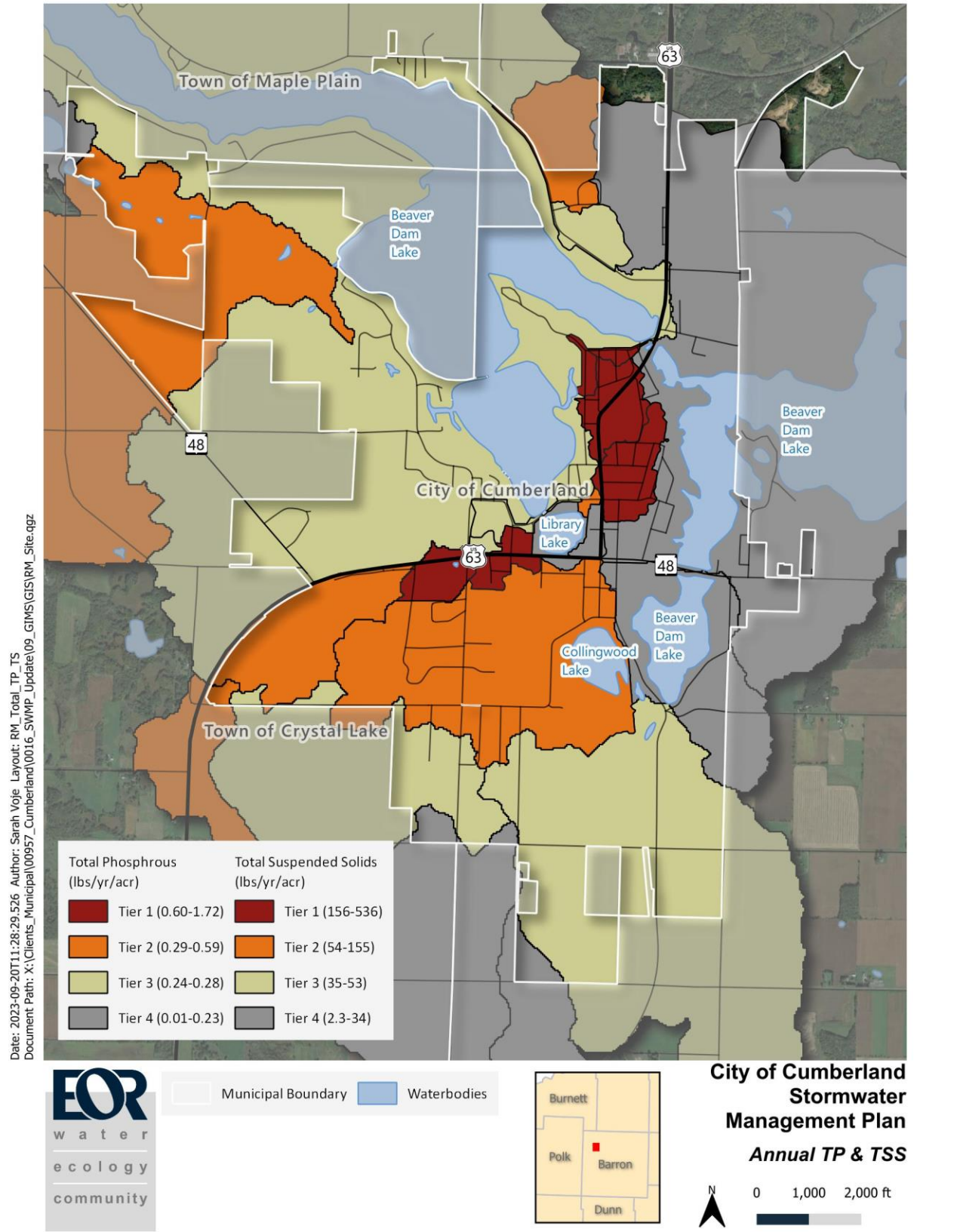

Figure 6. Average annual total phosphorus and total suspended solids leaving city subwatersheds normalized by subwatershed area (existing land use).

6. STORMWATER MANAGEMENT RECOMMENDATIONS

Priority Subwatersheds

Those subwatersheds identified as having the highest average annual TP and TSS loading rates on a per acres basis are priority watersheds for stormwater management improvements. The second, third and fourth highest tiers of pollutant loading are to be considered in that order for ongoing stormwater management improvements except in the rare circumstance where special conditions may favor implementation out of order.

Library Lake Restoration

At the time of the first (2010) Cumberland stormwater management plan, 9 of 11 priority subwatersheds were in the Library Lake drainage area. The Beaver Dam Lake Management District has worked tirelessly over the last 10+ years to implement recommended BMPs within these subwatersheds to provide stormwater treatment of runoff. These projects included stormwater wetlands and bioretention basins as well as an iron-enhanced sand filter located at each corner of Library Lake

Table 9 identifies the phases of Library Lake restoration. Phases 1 through 3 that specifically address stormwater management. Phases 1 and 2 have largely been completed, or are in progress, as of 2022. Phase 3 through 5 are still in the future of restoration efforts centered around Library Lake

Table 9. Library Lake restoration project phases.

Phase 1	Stormwater Improvements and Park Development: acquire land and construct stormwater practices and park.
Phase 2	Lake and Shoreline Restoration: remove accumulated sediments.
Phase 3	Restore Hydrology: restore Library Lake outlet under highway 63/48.
Phase 4	Community Connections: create non-motorized trail passage over highway 63/48 and in the city of Cumberland.
Phase 5	Grove Street Bridge: raise and widen the Grove Street Bridge to accommodate boat traffic safely.

Phase 1 - Stormwater Improvements and Park Development

Stormwater Improvements

Treatment wetlands and ponding, with pretreatment structures and forebays to allow sediment removal before discharge, have been the primary method that has been employed to treat stormwater.

The Neurer Pond was the first project completed in 2012 which utilized a water quality pretreatment system to capture sediment and divert low flow storm events from the Northwest/Grove Street drainage area. In 2017 the Northeast treatment pond was completed

utilizing a water quality pretreatment unit to capture sediment before final treatment in a stormwater wetland. As a part of this project, sump structures were installed to capture sediment that had been discharging directly from the city parking lot on the east side of Library Lake. In the winter of 2017, significant dredging of Rabbit Island Bay along 3rd Avenue was completed to remove decades of accumulated sediment and provide improved navigation for boaters. In the summer of 2017, the city completed the reconstruction of Lake Street with the intention of providing future stormwater treatment opportunities. In the summer of 2018, construction was completed on the Library Lake SW stormwater wetland. This redirected the flow of the Hwy 48/64 runoff from direct discharge to Library Lake into a pretreatment unit before final scrubbing through a four-tiered wetland treatment system. In 2018, stormwater treatment devices were installed on 3rd Ave. and two locations along Jeffery Blvd. to capture sediment in sump type structures before discharge to the lake. In 2021, construction started on the crown jewel of the Library Lake Restoration Project. Runoff from the city parking lot was redirected to stormwater treatment pond on the Southeast corner of Library Lake. This is the first of a three-phase project. Phase Two will direct the discharge from the stormwater pond to an iron enhanced sand filter for final treatment to reduce soluble phosphorous. A large rain garden will be included to treat direct drainage for Hwy 48/64. Phase three of the project will include a porous pavement parking lot and restoration of the site as a city park.

Park Development

Native plantings and natural ecosystem functions will be integrated into the park development as much as possible to create and enhance aquatic and terrestrial habitat, as well as provide year-round aesthetic interest. Because of the park's proximity to downtown, it will be a highly utilized landscape by the pedestrian, boat, bicycle, and vehicular traffic that will pass through and around. The park will display the character of the project's natural components and be an intentional, cared for public space.

A naturalistic approach to planting and design will be framed with structures and turf grass to blend into the surrounding neighborhood and create an ordered look that people most commonly associate with traditional parks. The landscaping will be functional as well as beautiful, treating stormwater as well as forming the structure of the park. Nature-based education will be an important goal of the park master plan. The park will provide a naturalistic landscape and existing natural ecosystems for environmental education that will be supplemented with interpretive signage.

Phase 2 - Lake and Shoreline Restoration (Sediment Removal)

Sediment removal within selected areas will provide navigation channels to support boating within the lake while protecting the lake's fish spawning habitat. Three methods of dredging were researched. Suction dredging, dragline dredging, and winter excavation. Winter excavation is the selected method for sediment removal in part because less unnecessary disturbance results and more accurate finish grades are possible. The other methods of dredging pollute the water and don't provide precise bottom sensing.

The most economical and precise way to selectively dredge Library Bay is to dam the Grove Street Bridge and pump to reduce lake levels in the fall. To minimize recreational and aquatic

disturbance, a maximum of two feet of drawdown below the normal water level is being proposed and will be conducted during the months of November through March. This period of operation allows sediments to compact, thus lessening the volume of excavation and associated disturbance. Furthermore, winter dredging limits the suspension of sediments and potential deposition.

The majority of the proposed dredging is concentrated in the cattail marsh on the SE corner of Library Lake and in the area of the Grove Street bridge. Sediment will be removed via an excavator and properly disposed. An aerator will be installed to ensure adequate oxygen supply to fish during the drawdown if the DNR determines that fish are present and oxygen level is insufficient.

Phase 3 - Restore Hydrology

Restoring the southwest outlet shown in the 1888 historical map would establish a second control station and increase flow through Collingwood Lake to the Hay River. Following storm events, increased water flow through Library Lake will benefit the lake by displacing high nutrient stormwater in Library Lake with lower nutrient waters from upstream portions of Beaver Dam Lake. Outlet restoration will also reduce “bounce” after storms by bringing the lake’s water level to normal more quickly following storm events. Restoration of the southwest outlet and channel corridor will result in Library Lake flood improvements. The existing flood elevation (i.e., 100 year event) for Library Lake is 1,233 feet NGVD29 (vertical datum).

Phases 4 and 5 of the master plan include additional park and trail system and improvements to the Grove Street Bridge.



Legend

 Stormwater Treatment Facilities

**Stormwater Treatment Facilities
 Library Lake, Cumberland, WI**

0 40 80 160 240 320 Feet



October 1, 2021

Figure 7. Stormwater Improvement Projects Completed Around Library Lake since 2010

7. STORMWATER BEST MANAGEMENT PRACTICES

This chapter provides a list of stormwater best management practices (BMPs) that the City of Cumberland may implement to achieve the city’s stormwater management goals. These BMPs seek to follow the principals of Low Impact Development (LID) which aims to mimic the natural hydrology of the watershed through encouraging the infiltration, evaporation, treatment, and retention of stormwater runoff, thereby reducing the negative effects of too much runoff. In general, the principals of LID are in line with the goals of the City of Cumberland to reduce stormwater runoff, treat runoff for water quality, and protect the abundant native aquatic and shoreline habitat.

For this report the BMPs have been organized into three subsections: those non-structural practices and techniques that can be specified during the planning and design phase (Better Site Design), those structural BMPs that can be integrated into a site (Structural BMPs) and those municipal programs and practices that keep pollution at bay and keep the BMPs functioning as intended for a long time (Programmatic BMPs). See Appendix A for more detailed information on each BMP.

Better Site Design Practices

- o Amended Soils
- o Native Landscaping
- o Reducing Impervious Cover
- o Natural Area Protection
- o Open Space Design
- o Buffers

Structural BMPs

Pre-treatment & Filtration Practices

- o Settling Devices
- o Screens
- o Vegetated Filters

Infiltration, Evaporation and Detention Practices

- o Bioretention
- o Permeable Pavement
- o Infiltration Practices
- o Vegetated Swales
- o Level Spreader
- o Stormwater Tree Trenches
- o Rainwater Harvest & Reuse
- o Green /Blue Roofs
- o Stormwater Ponds
- o Stormwater Wetlands

Phosphorus Reduction Practices

- Iron Enhanced filters

Programmatic BMPs

Municipal Programs & Standards

- Street Sweeping Program
- Erosion & Sediment Control Standards
- Hazardous Material Storage and Handling Standards
- Winter Roads Materials Management Standards
- Fertilizer/Chemical Application Management Standards
- Rain Barrel Rebate Program
- Rainwater Harvesting System Standard

Potential Regulations / Ordinance

- Stormwater Utility
- Development Requirements

Training & Education

- Training for City Staff and Contractors
- Public Education

In addition to implementing the BMPs listed above, the City of Cumberland should consider establishing an Erosion & Sediment Control (ESC) program that includes construction standards specific to reducing sediment provided to developers, training for city staff and the requirements to provide an ESC report with new development applications.

The ESC Report should include:

1. Discuss the potential sources of sediment and other pollutants on the site during the construction process.
2. Identify areas of the site where flows concentrate.
3. Identify who will be responsible for overseeing the implementation and maintenance of the ESC measures.
4. Identify a chain of responsibility between the owner, general contractor, subcontractors and vendors involved in the project. Inspectors, designers, prime contractors, and subcontractors should review the ESC Report at pre-bid, pre-construction, weekly meetings, and additionally as needed. Updates and changes should be made and communicated throughout the construction team. Note: do not discount the vendors, many times problems are the result of a lack of communication between the contractor, vendors, and delivery drivers (e.g. tracking mud on the streets).
5. Identify temporary sediment basins and how they will be managed.
6. Identify the permanent stormwater management system and how it will be managed.

7. Identify erosion protection practices such as construction phasing and minimization of land disturbances, vegetative buffers, temporary seeding, sod stabilization, horizontal slope grading, preservation of trees and other natural vegetation, and temporary and permanent vegetation establishment.
8. Identify sediment control practices such as installation and maintenance of perimeter controls, practices to control vehicle tracking, control of temporary soil stockpiles, and protection of storm drain inlets.
9. Identify dewatering and basin draining practices to prevent discharge of sediment laden water and downstream erosion and scour of by discharged water.
10. Identify inspection and maintenance practices to ensure that inspections occur weekly or after individual rainfall events, are routinely recorded, that repairs and maintenance and replacement of ineffective practices are completed in a timely manner (see the ESC Guide).
11. Identify pollution prevention management measures to address proper storage, collection and disposal of solid waste, oil, paint, gasoline, and other hazardous materials, and fueling and maintenance areas.
12. Include a strategy for retaining records and who is responsible for them.

The city should also consider training staff on ESC best practices. The following is a condensed list of recommended ESC BMPs to discuss in a training program:

- Site phasing
- Construction entrances
- Protecting natural vegetation and undisturbed areas
- Low impact development
- Temporary diversions
- Temporary down drains
- Sediment retention basins
- Dewatering
- Perimeter control
- Stockpile protection
- Surface roughening and slope tracking
- Minimize slopes
- Storm drain inlet protection
- Outlet protection
- Temporary and permanent stabilization
- Specific BMPs related to working near or around water



Figure 8: Installed silt fence will minimize sediment leaving a site and contaminating surface waters

In addition, the city should implement development requirements into its zoning regulations, engineering standards, or other local ordinance including the following:

- Impervious cover limit requirements
- Downspout disconnection requirements
- Tree retention requirements
- Minimum soil volume requirements
- Water body buffer requirements
- Volume control requirements for stormwater runoff
- Operation & Maintenance Manual requirements

See Appendix A for more information on these types of requirements.

Training for City Staff and Contractors

To support the successful implementation of BMPs within the city, the following training is recommended for city staff and external contractors:

- LID design and construction
- Vegetation Maintenance
- Cleaning & Sediment removal
- Erosion & Sediment Control during construction

To encourage the adoption or support the creation of the proposed municipal standards, training on the following is recommended:

- Erosion and Sediment Control
- Hazardous Material Storage and Handling
- Winter Roads Materials Management
- Fertilizer / Chemical Application

8. ORDINANCE GAP ANALYSIS

Purpose

The purpose of the ordinance gap analysis is to assist the city of Cumberland in identifying how its ordinances could improve stormwater management and water quality to enhance and maintain the quality of the city's water resources.

It is apparent from the city of Cumberland 2017 Comprehensive Plan that effective stormwater management is a priority based on the Goals and Objectives outlined below. The associated recommendations for ordinance additions, alterations, and programs provided within each subsection will assist in closing the gaps between practice and intent. Unless otherwise noted all ordinance referenced are from the City of Cumberland Municipal Code.

Housing and Demographics

Goal: Guide new housing development into areas that minimize impacts on sensitive natural resources (lakes and wetlands) so that the city continues to be an attractive place to reside.

Objective: Encourage development in areas that will not result in property or environmental damage. New residential development and residential infill development should be consistent with and not detract from the general character of the neighborhood.

- b. Encourage "low impact" development that strives to retain natural vegetation that can help reduce storm water runoff, flooding, and minimize impact on water quality.
Encourage the retention of natural vegetation, especially along lakeshores

Closing the gap to meet the Goal and Objectives:

- Require that new and infill developments follow the stormwater management requirements for:
 - Total Suspended Solids,
 - Peak Discharge,
 - Infiltration and
 - Protective Areasas outlined in 'NR 151.12 Post-construction performance standard for new development and redevelopment' from the Wisconsin State Code, Environmental Protection- General- Chapter NR 151: Runoff Management.
- Clarify the meaning of 'Hard Surface' in '17.39 (8) Surfacing' within the Parking and Loading section to allow for permeable alternatives for off-street parking areas.
- Consider altering the requirement for parking spots, specific for those spots that are provided over the minimum requirements (as outlined in 17.30 Parking Space Requirements) be created in permeable materials to reduce runoff from potentially unused impervious areas.
- Require grading of impermeable driveways into landscaping where applicable instead of into the municipal system
- Ban connection of residential downspouts to the municipal system for all new and retrofit development, encouraging the use of stormwater BMPS for areas that would not allow for natural infiltration without impacting neighboring properties.

Utilities and Community Facilities

Goal: Provide residents with reliable and clean water supply, and a sewer collection system and wastewater treatment plant, which meets applicable laws and regulations in a cost-effective manner.

Objective: Determine if an adjustment in management practices is necessary.

- c. Protect the City’s wellheads from development and uses that may pose a risk to groundwater quality. Continue to monitor and enforce wellhead protection areas.
- d. Continue current efforts and improvements to address phosphorus effluent permit limits for the wastewater treatment plant.

Closing the gap to meet the Goal and Objectives:

- Educate on and enforce the Well Head Protection Program as outlined in the City Ordinance 13.017.

Goal: Implement the City of Cumberland Stormwater Management Plan

Objective: The City of Cumberland will require necessary stormwater best management practices for new development and develop solutions to keep pace with evolving water quality regulations.

Objective: Establish stormwater rates and financing mechanisms to fully implement the stormwater utility help pay for stormwater management projects and activities.

Objective: Work with Beaver Dam Lake Management District to increase awareness about water quality issues in Cumberland.

Closing the gap to meet the Goal and Objectives:

- Vote or pass resolution to increase tax levy to fund stormwater management as per the Stormwater Utility outlined in Ordinance 13.025
More information on exceeding a levy can be found:
<https://www.revenue.wi.gov/SLFReportscotvc/exceeding-levy-limits-fact-sheet.pdf>
<https://www.wisctowns.com/information-library/>
- Require that new and infill developments follow the stormwater management requirements for:
 - Total Suspended Solids,
 - Peak Discharge,
 - Infiltration and
 - Protective Areasas outlined in ‘NR 151.12 Post-construction performance standard for new

development and redevelopment' from the Wisconsin State Code, Environmental Protection– General- Chapter NR 151: Runoff Management.

Agricultural, Natural, and Cultural Resources

Goal: Conserve, protect, manage, and enhance the City's natural resources, including but not limited to, lakes, rivers/streams, wetlands, groundwater, forestlands, and other wildlife habitats to provide the highest quality of life for the City of Cumberland's citizens and visitors.

Objective: Enforce setback requirements for water resources by enforcing City shoreland standards when applicable and educate residents about the importance of natural areas and wildlife corridors.

Objective: Endorse the Wisconsin Department of Natural Resources watershed initiatives to educate shoreland and basin property owners on the appropriate safe levels, application, timing and safe types of fertilizers and pesticides applied to lawns and fields in the City.

Objective: Work with the BDLMD to protect surface water quality, improve aquatic habitat, control invasive species, and related public education.

- a. Implement the recommendations of the City's Stormwater Management Plan.
- b. Support efforts to continue monitoring of the quality and quantity of runoff, such as phosphorus and sediment loading.

Objective: Promote the establishment and maintenance of natural buffers along water resources.

- a. Encourage Barron County and the Wisconsin Department of Natural Resources to fund buffer strips along streams and the lakeshores.
- b. Collaborate with state and local organizations whose charge is to enhance water quality.

Objective: Educate the public on best management practices that will ensure the protection of natural resources. Publish or obtain information that can be distributed to residents on the disposal of hazardous materials, such as paint, waste oils, computers, insecticides, etc.

Closing the gap to meet the Goal and Objectives:

- Create an ordinance banning the use of certain Pesticides and Fertilizers within Shoreland-Wetland Zoning District
- Create an Illicit Discharge Program Ordinance

Land Use

Goal: Preserve Cumberland's existing character

Objective: Encourage low impact development especially in areas near sensitive natural resources.

a. Coordinate with Barron County and the BDLMD to consider additional requirements, incentives, and demonstration projects for conservation and runoff management in and near lakeshore areas. These requirements and best management practices should work to minimize uninterrupted hardscape, provide areas of stormwater storage, promote infiltration of stormwater, and encourage natural buffers zones and screens along roads and sensitive natural resources (i.e., steep slopes, wooded areas, wetlands, lakes, etc.).

Closing the gap to meet the Goal and Objectives:

- Create maximum lot clearance % impervious area requirements for lakeshore areas to minimize impervious cover and encourage infiltration

9. PUBLIC OUTREACH, INFORMATION & EDUCATION FRAMEWORK

Substantial water quality improvements are made with structural best management practices (BMPs), but part of the solution to water quality improvement is public education. Education programs create an awareness of and appreciation for the city’s water resources and teach people how to reduce polluted runoff from their areas of influence (yards, community centers, places of work) or they can be effective tools to generate public understanding (and therefore support) of city stormwater management initiatives (e.g., structural, or programmatic BMPs, stormwater utility, ordinance revisions).

The purpose of this section is to develop a framework for education opportunities /programs that facilitate implementation of Stormwater Management Plan goals within identified target groups.

The city’s 2017 Comprehensive Plan also identifies specific stormwater-management-related objectives and action items for public education, as listed below:

- **Objective:** Work with Beaver Dam Lake Management District to increase awareness about water quality issues in Cumberland
- **Objective:** Enforce setback requirements for water resources by enforcing City shoreland standards when applicable. Educate residents about the importance of natural areas and wildlife corridors.
- **Objective:** Endorse the Wisconsin Department of Natural Resources watershed initiatives to educate shoreland and basin property owners on the appropriate safe levels, application, timing and safe types of fertilizers and pesticides applied to lawns and fields in the City
- **Objective:** Educate the public on best management practices that will ensure the protection of natural resources.
 - a. Publish or obtain information that can be distributed to residents on the disposal of hazardous materials, such as paint, waste oils, computers, insecticides, etc.

Education around proper stormwater management can be multi-faceted, actively taking education opportunities to people and interested partners, or passively providing more information on well-placed signage and websites.

Consider passive education options (site signage, websites, brochures, etc.) which would allow people to learn via their own initiative and be available for those who interact with a site or go looking for more information. Information could include:

- Drain markings to inform citizens that this drain connects directly to lake
- Signage at the waterside with information about issues that affect water quality
- BMP explanatory signage at highlighted projects, especially for any features that may not be visible from the surface
- Signage around Sustainable Landscaping and its benefits.
- Signs to manage people’s expectations if a site looks more natural than other landscaped areas. (Show example “This is a Rain Garden” sign).

- QR codes on outdoor signage and brochures that link to more information on the city’s website.



Active education options (tours, workshops, talks, etc.) bring people together for a specific purpose, and could include:

- Workshop on BMPs during the installation of a site feature so people could learn about their function and the benefits they provide to the community.
- Trainings to help people implement a rain garden on their own property.
- Training for City staff and Contractors on the maintenance of BMPs
- Native Flower Tour which could teach people about the benefits of native plants and offer seed giveaways.

Opportunities also exist to create partnerships with local environmental stewardship groups to provide the training or to host volunteers for maintenance where it may be applicable.



Target Audiences

The target audiences for achieving water quality improvement and stormwater volume reduction inform program design, content, and outreach mechanisms. Target audiences are identified based on their ability to bring about change, their contribution to the problem or their geographic proximity to the problem.

- Construction Professionals
- Residents
- Occasional Users
- Policy Makers and Government Staff
- Business Owners
- Natural Resource Partnership Groups
- Students

Objectives and Potential Opportunities

Information about the target audiences' interests, preferences and activities can be gathered through surveys, focus groups, discussions, and review of reports and databases and is recommended to tailor educational programming (e.g. delivery methods, communication methodologies) to the audiences.

Some educational opportunities and programming may be best achieved through partnerships with the Beaver Dam Lake Management District, the Wisconsin Department of Natural Resources, University of Wisconsin Extension, Barron County Land Conservation Department, other area Lake Districts or Associations, or other entities involved in education and outreach on water resource issues.

Overall Education Objective: Ensure that all audiences have a base understanding of how stormwater runoff and its path through infrastructure (sewer, ditches) to a water resource can affect the function (erosion, habitats) and water quality of that resource (stream, lake, etc.).

Construction Professionals

Construction Professionals are those individuals who plan, implement and construct land developments, new construction and redevelopment. Including designers, they can protect and improve the resources of Cumberland through their actions as developments and buildings are designed, constructed or re-built. The education objective for this audience and potential opportunities focusses on increasing the understanding of the benefits of BMPs to increase implementation and to ensure communication with landowners and building managers on the function and maintenance of BMPs.

Education Objective: To have professionals understand the suite of BMPs available, how to install them, how to maintain them and what benefits they bring so that they are integrated into plans and promoted within the city.

Potential education/ outreach opportunities:

- Better Site Design training
- BMP design training
- BMP installation and maintenance training
- Sediment and Erosion Control training
- Salt Management Training

Residents

Homeowners, landlords, property owners, and residents need specific knowledge and skills in order to implement and maintain simple small-scale stormwater BMPs which can have a big impact when adopted widely. The education objective and opportunities for landowners and residents are focused on BMPs that can be easily implemented and maintained: shoreland vegetation, fertilizer and leaf management, and small scale BMPs such as raingardens.

Education Objective: To have residents (property owners and tenants) understand how the maintenance and upkeep of their property can impact water quality through the reduction of runoff and minimization of hazardous substances (fertilizer, sediment, etc.).

Potential education / outreach opportunities:

- Raingarden installation and maintenance workshop
- Shoreline Buffer installation and maintenance workshop
- Flyers / Pamphlets on safe use of fertilizers and leaf management in the fall
- Flyers/ Pamphlets encouraging infiltration and runoff from property
- Signage at boat launches on invasive species and proper boat cleaning
- City lead workshop on native plants and sustainable landscaping
- Volunteer planting events
- Citizen Science program for residents to get involved in monitoring their lake (water clarity, pH, erosion, etc.)

Occasional Users

Occasional users of the city's water resources, many of whom are not residents, have a particular need to see the importance of protecting the lake in which they recreate. The educational objective and opportunities for occasional users of the city's lakes are focused on aquatic plants, lake recreational use, and the management of aquatic invasive species such as Eurasian Water Milfoil.

Education Objective: To ensure that occasional users of the City's water resources are aware of any requirements that they must follow and why to protect the water quality.

Potential education / outreach opportunities:

- Flyers / Pamphlets on stormwater management/water quality requirements - provided to all hotels, guest houses, rentals etc. to have prominently displayed or part of information package
- Signage at boat launches on invasive species and proper boat cleaning
- Information Blitz during "Opening Weekend"/ long weekend / Rutabaga Festival (Catch the majority of seasonal users at one time with information and requirements.)
- City lead workshops on native plants and sustainable landscaping
- Volunteer planting / clean-up events
- Citizen Science program to get involved in monitoring the lake (water clarity, pH, erosion, etc.)

Policy Makers and Government Staff

Elected officials and government staff have the unique ability to make policy decisions for the stormwater program. Included in this category are education administrators and municipal staff. Each of these audiences has high visibility and can set the bar for stormwater management and to lead by example. Policy makers and staff involved in planning, zoning, land conservation, parks and public works are of particular importance. The education objective and opportunities for policy makers and municipal staff focus on consistent understanding of regulations, BMPs, and communication with the community.

Education Objective: Policy makers and municipal staff understand the city's stormwater management requirements and the importance of BMPs enough to integrate them into City plans and policies, and support residents, business owners and contractors in meeting them.

Potential education / outreach opportunities:

- Better Site Design training
- BMP training on applicability, benefits provided, and long-term considerations (maintenance and rehabilitation)
- BMP Pilot Project on a municipal site with signage and 'opening' event after it is installed.
- Salt Management Training

Business Owners

Businesses and industrial facilities as well as gas stations and fleet handling facilities have the potential to discharge pollutants such as fertilizers, pesticides, heavy metals, petroleum products and other chemicals through stormwater runoff. Small business owners typically manage their own parking lots and landscaping, whereas owners of a unit in a strip mall do not. Particular companies of interest include, but are not limited to, lawn care companies, painters, golf courses, boat storage and cleaning companies, mobile cleaning operations and any business or facility with outdoor storage. Business owners and people working in the private sector do not necessarily live in the city and, therefore, require a delivery method and message different than those who, as residents, have an inherent stake in the city and the state of its aquatic and natural resources. The education objective and opportunities for business owners and those working in Cumberland are focused on increasing the understanding of site design and property management decisions.

Education Objective: Business owners/operators will understand the stormwater / runoff requirements, the importance of meeting them, and the suite of BMPs available to achieve them.

List of potential education, outreach opportunities:

- Pilot Project in partnership with the city – Roadside or parking lot swale
- Workshop on Stormwater Management Issues and what businesses can do
- Pamphlets on proper site maintenance to improve water quality
- Salt Management Training

Natural Resource Partnership Groups

Natural resource partnership groups such as the Beaver Dam Lake Management District can be valuable partners for the city in their education efforts. As a separate avenue for conveying stormwater management information, these groups have the unique ability to reinforce the city's efforts and reach additional audiences. The education objective and opportunities for natural resource partnership groups focus on information on the benefits of stormwater BMPs.

Education Objective: Natural resource partnership groups convey to all audiences the environmental benefits of stormwater BMPs.

Potential education / outreach opportunities:

- Educational Booth or table at local festivals / “opening weekend”
- Offer Site Tours of local water resources for occasional users
- Run a Citizen Science program to get others involved in monitoring the lake (water clarity, pH, erosion, etc.)
- Rain barrel fundraising sale to encourage disconnection
- Native Flower information event and seed sale to promote Shoreline Buffers

Students

The following objectives relate specifically to K-12 students. Students learn about their natural environment in school and can be active participants in the city's educational efforts. The

objectives for students are focused on active participation and understanding of resources and the interaction of the built environment with the city's natural resources.

Education Objective: Students participate in active community education initiatives (e.g. resource monitoring, shoreline planting, raingarden planting, storm drain stenciling).

Potential education / outreach opportunities:

- Volunteer planting / clean-up days
- Citizen Science program to get involved in monitoring the lake (water clarity, pH, erosion, etc.)
- Storm drain stenciling

THIS PAGE LEFT BLANK INTENTIONALLY

10. IMPLEMENTATION PLAN

Introduction

The implementation section of the city's Stormwater Management Plan includes programs, projects and capital improvements. The implementation plan identifies the specific projects, studies, and other activities necessary to implement the city's goals as identified through this and previous studies as well as through the public involvement process. The initiatives contained in the implementation plan seek to protect and improve city water resources and stormwater infrastructure. Inclusion of an initiative in the implementation plan is a statement of intent by the city of Cumberland. Final decisions on implementation rest with future decisions by the city Public Works Committee and, ultimately, the City Council to budget for and authorize the initiative. In many cases, implementation requires further action and/or approval and participation of other parties. The city will regularly evaluate the water resources needs within the city and make appropriate changes in priorities during the 10-year term of the implementation plan.

Over the 10-year period of this implementation plan, as information becomes available, priorities evolve, new concerns emerge, or new technical approaches are developed, the city will likely adapt the implementation plan to reflect this new information. The listing of initiatives in the implementation plan is not intended to exclude other initiatives consistent with the goals identified in this Stormwater Management Plan. If the new activity is widely different in scope or cost from that detailed in the implementation plan, plan amendments may be warranted. If not, the city could proceed with a new initiative under the existing implementation plan.

All projects in the implementation plan (including any future additions) will only be implemented with landowner approval and a formal agreement.

Implementation Plan Structure

Activities are organized into two main categories: Programs and Projects. Programs include the ongoing initiatives of the city with respect to stormwater management. Projects include efforts that occur in a defined period of time to address a specific concern. Projects include feasibility evaluations, studies, and capital improvements or construction projects.

Information regarding the anticipated initiatives, partners, and costs involved for each of the implementation activities is presented in the implementation plan table and in narrative sections for each activity area.

Subwatershed-based initiatives are discussed using a prioritization based on pollutant loading characteristics identified through water quality modeling conducted during development of this plan. Tier 1 Subwatersheds have the highest pollutant loading of all the subwatersheds city-wide and therefore are priority subwatersheds for pollutant source analysis and BMP implementation. Subwatershed pollutant loading is lower in Tiers 2 and 3, respectively. Tier 4 Subwatersheds have the lowest pollutant loading and are therefore a low priority for study and implementation; no Tier 4 Subwatersheds are yet proposed for implementation activities with the exception of the Beaver Dam Lake West Major Drainage Area. All Library Lake subwatersheds are addressed through the Library Lake Restoration initiatives.

Table 10. Implementation plan organization: categories and activities.

PROGRAMS
Site Plan Review Permitting & Enforcement
Stormwater Infrastructure Inspection & Maintenance
Pollution Prevention on City Properties
Aquatic Invasive Species Management
Monitoring and Data Assessment
Education & Outreach
Geographic Information System (Support for Stormwater Utility)
PROJECTS
Stormwater Utility Establishment
Ordinance Development & Revisions
Stormsewer Outfall Dredging Policy and Operation and Maintenance plan
Riprap at Stormsewer Outlets
Pipe Inspection and Maintenance
Stormwater Infrastructure Improvements
Winter Maintenance Materials Management
Library Lake Watershed Stormwater Improvements and Park Development
Library Lake Restoration and Shoreline Restoration
Library Lake Outlet Restoration
Pollution Prevention Plans for Industrial Sites
Purchase of Vacuum Street Sweeper
Collingwood Lake Monitoring
Collingwood Lake Stormwater Management Facility Identification and Siting
Cemetery Bay Watershed Stormwater Management Facility Identification and Siting
Rabbit Island Bay Watershed Stormwater Management Facility Identification and Siting
Norwegian Bay Watershed Stormwater Management Facility Identification and Siting
Landlocked Basin Stormwater Management Facility Identification and Siting
Vermillion River Watershed (Cumberland Municipal Airport) Stormwater Management Facility Identification and Siting
Beaver Dam Lake West Watershed Stormwater Management Plan for Future Development

Implementation Plan Table

The implementation plan table includes a general timeline of how the implementation initiatives could be implemented over the 10 years of the Stormwater Management Plan. Priority initiatives are slated to occur early (years 1-3) or in the middle (years 4-5) of plan implementation. Actions that are currently of lower priority are scheduled later (years 5-10) in the 10-year period of the implementation plan.

Implementation Activity Narratives

PROGRAMS

Site Plan Review Permitting & Enforcement

Description and Purpose of Program

The City will review site plans for consistency with stormwater ordinances and will issue and enforce permits, including conducting site inspections. Many costs associated with the permitting and enforcement program can be recovered through permit fees. To support the implementation of updated stormwater management ordinances, the city will provide technical assistance and guidance to permit applicants.

The city or its engineering support will review site plans and project proposals for consistency with the City's stormwater management ordinances. The City's inspector and enforcement officer will inspect sites under construction for consistency with erosion control and stormwater ordinances and will ensure that stormwater management practices are constructed according to the plans.

The city will also provide technical assistance to permittees who are implementing better site design principles and innovative stormwater management practices. The assistance may be by city staff or in coordination with a consultant or the Beaver Dam Lake Management District. In addition, technical assistance can be supported by educational efforts or guidance materials.

Stormwater Infrastructure Inspection & Maintenance

Description and Purpose of Program

The inspection and maintenance of stormwater infrastructure is key to the long-term function of the stormwater management system. The city will inspect stormwater infrastructure and conduct maintenance as needed as identified through the inspections. The city will also conduct recurring maintenance activities such as street sweeping.

The city or its engineering support will conduct a visual inspection of all stormwater management systems. More detailed inspections (e.g. sediment depth, runoff testing, etc.) will be conducted as indicated by the visual inspection. The [*Stormwater Treatment: Assessment and Maintenance*](#)¹ manual can be used as a guide and reference for the inspection process. Stormwater facilities will be maintained based on the needs identified through inspections.

The city will conduct regular maintenance such as street sweeping, catch basin cleaning, and maintenance of stormwater management facilities. Key areas for focused street sweeping are snow storage sites. Sweeping should be conducted in snow storage locations in the spring as sediment from the snow piles is exposed to eliminate the transport of this material to nearby lakes.

¹ Gulliver, J.S., A.J. Erickson, and P.T. Weiss (editors). 2010. *Stormwater Treatment: Assessment and Maintenance.* University of Minnesota, St. Anthony Falls Laboratory. Minneapolis, MN. <http://stormwaterbook.safl.umn.edu/>

To improve water quality benefits of street sweeping, it is recommended that the city purchase a regenerative-air or vacuum street sweeper when replacement of the current sweeper is necessary (see Purchase of Vacuum Street Sweeper Project).

Pollution Prevention for City Properties

Description and Purpose of Program

The City will plan for and conduct regular pollution prevention practices on city properties. In addition, the City will encourage pollution prevention activities on private properties and will provide technical support for implementing pollution prevention measures.

The city will prepare and implement a pollution prevention plan to address general practices of the city such as landscaping maintenance and cleanup (e.g. grass clippings management), street sweeping, winter maintenance of parking lots, sidewalks and roads (e.g. calibrated salt application equipment), stockpiling of materials (e.g., proper storage of mulch, sand and salt).

Aquatic Invasive Species Management

Description and Purpose of Program

In partnership with the Beaver Dam Lake Management District, the city will work to prevent the transport and spread of aquatic invasive species through existing programs and through education efforts. The city will continue to apply for WDNR Healthy Lakes Grants to provide education and inspections the boat launch during times with higher numbers of boats entering and exiting the lake (e.g. weekends) to demonstrate proper boat cleaning measures, check that boats are following these measures, and to discuss why these measures are needed.

Monitoring and Data Assessment

Description and Purpose of Program

The city will support the monitoring efforts of the Beaver Dam Lake Management District to annually measure key water quality parameters in its lakes. This ongoing monitoring allows the Beaver Dam Lake Management District and the City to track changes in lake quality over time to adjust its stormwater management strategy accordingly.

The city may also consider developing and implementing a lake inflow monitoring program or BMP monitoring program. The program could measure key water quality parameters such as suspended solids, total phosphorus, and flow in the inflow to the lake. This type of monitoring would reflect changes in the content of runoff more quickly than measurements in the lake. This monitoring could also be conducted close to constructed water quality practices before and after construction to measure the impact of the project.

Education and Outreach

Description and Purpose of Program

The City will develop and implement an education program to inform and engage the City's stakeholders including landowners, private companies, students, lake users, policy makers and government staff, and local lake districts and associations.

The city will utilize printed and/or web-based educational materials that present stormwater management and water quality improvement information in a clear and engaging manner. The materials will be targeted to specific audiences and different topics:

- A. Targeted to Landowners and the Private Sector
 - 1. Water conservation informational flyers sent with water bills (see Appendix C for example).
 - 2. Educational flyer regarding ordinances, regulations and environmental impacts of illicit discharges to storm sewers.
 - 3. Share education materials with Beaver Dam Lake Management District for distribution to members and lakeshore owners. Materials could address topics such as directing downspouts to pervious areas, reducing impervious areas, constructing rain gardens, using rain barrels and maintenance techniques including shoreland buffers, leaf litter and grass clipping management.
 - 4. Updates on City-led projects such as the Library Lake restoration.
 - 5. Informational sheet on stormwater utility (if developed).
- B. Targeted to Lake Users
 - 1. Eurasian watermilfoil and curly leaf pondweed educational flyers and signage at lake public accesses.

The city may also implement interactive educational events and workshops to actively demonstrate stormwater management and water quality protection practices. The events will be planned to target specific audiences and different topics:

- A. Targeted to Landowners
 - 1. Workshops on designing and establishing a shoreland buffer or building a rain garden. Perhaps partner with local garden centers who could offer shoreland buffer or raingarden plant kits to attendees.
 - 2. Municipal staff representative at Beaver Dam Lake Management District meetings to act as a liaison and provide outreach.
 - 3. Share announcements of upcoming events with Beaver Dam Lake Management District for distribution to members and lakeshore owners.
- B. Targeted to All Residents and Students
 - 1. Storm drain stenciling (e.g., No Dumping, Drains to Lake) with introductory presentation on stormwater runoff and environmental impacts
- C. Targeted to Policy Makers & Government Staff
 - 1. Form a coalition of all government agencies whose land drains to Beaver Dam Lake and meet regularly to discuss coordination of protection and implementation activities.

The City may consider working with the Beaver Dam Lake Management District to develop and implement incentives or cost-share programs to support the implementation of smaller distributed practices (e.g., buffers and raingardens) on private properties throughout the City. The programs could provide incentives such as technical support for raingarden or buffer design or could provide some level of funding to assist in implementing projects and engaging the

community in the City's efforts. The funding would likely only support projects where stormwater standards do not apply (e.g., no construction or site alteration planned other than the new practice).

PROJECTS

Ordinance Development & Revisions

Description and Purpose of Project

Update and/or develop ordinances to encourage and support better site design and stormwater management through specific standards and appropriate zoning. Model ordinances such as the Sustainable Development ordinances (<http://www.crplanning.com/susdo.htm>) could be used as a starting point for the revision process. Through an ordinance development and revision process the city will evaluate and revise current ordinances to address the concerns identified in Section 8 of this report. In addition, the city will periodically review current ordinances and modify as needed to address new concerns, areas needing clarification, and any other refinements that have been identified.

In order to support better site design and effective stormwater management, the City will evaluate and revise current ordinances to address, at a minimum, the following issues identified in Section 8 of this report:

- Whether ordinances are adequately requiring that right-of-way and paved portions of streets be as narrow as feasible.
- Adopting street, sidewalk, and right-of-way standards for all residential zone standards.
- Whether parking standards are requiring more spaces, and thus more impervious surface, than needed on a regular basis.
- Clearly identifying that low impact and better site design stormwater management practices (i.e., rural section roads, curb cuts to stormwater management practices, permeable pavements) are allowed and preferred on all sites and roadways
- Revising stormwater management standards to fully support and encourage low impact development and better site design stormwater management methods (i.e. swales, raingardens, bioretention).
- Allowing porous pavement materials for driveways, sidewalks, trails and parking lots (i.e., porous pavers, porous concrete, porous asphalt, open grid systems)
- Requiring open space to be consolidated into larger or more contiguous units.
- Requiring that a portion of the open space be managed in a natural condition.
- Consider buffer standards.
- Include more specificity on requirement for stormwater management, with focus on water quality treatment requirements, volume, and rate control.
- Develop incentive programs for developer and landowners to conserve non-regulated land.

The city will periodically review ordinances to address areas needing clarification, updated policies and procedures, emerging issues, and other refinements that have been identified through ordinance implementation and enforcement. It is estimated that ordinance review will occur every five years on average.

Storm Sewer Outfall Dredging Policy

Description and Purpose of Project

Outfall dredging is needed on a regular basis at a number of locations in the city. Outfalls are the location where a storm sewer system enters a lake. If stormwater management practices do not exist or are not numerous enough or large enough to capture the sediment contributed by the watershed, sediment accumulates where the storm sewer enters the lake. The DNR regulates the dredging of lakes and the disposal of excavated sediment. The city will work with the DNR to establish a policy or protocol that can be applied to all outfalls within the city in order to streamline the process of sediment testing for disposal.

Riprap at Storm sewer Outlets

Description and Purpose of Project

The city will add riprap to storm sewer outlets as necessary.

Pipe Maintenance

Description and Purpose of Project

The city will conduct pipe maintenance on a regular basis

Stormwater Infrastructure Improvements

Description and Purpose of Activity

The City of Cumberland stormwater infrastructure is extensive and particularly dense in the downtown and adjacent areas. Stormwater infrastructure can degrade with age and cause water quality and flood control problems such as sediment deltas, erosion, or deterioration of stormwater piping. The purpose of these initiatives is to provide for significant stormwater infrastructure improvements apart from routine maintenance and independent of subwatershed-based BMP implementation initiatives.

Downtown Infrastructure Investigation

The storm sewer system serving the city is old and is suspected to be degrading. This project will televise the pipe to determine repair and replacement needs. Needed repairs and replacements will be conducted based on the results of the investigation.

Catch Basin Stormwater Treatment

This project will site and design sediment traps or water quality treatment inserts in catch basins, where feasible throughout the city. Devices will reduce sediment discharge to receiving waterbodies and will reduce loading of pollutants associated with sediment. Water quality treatment inserts may also provide treatment of some dissolved constituents (pollutants not associated with sediment particles).

Winter Maintenance Materials Management

This project will provide impervious surface and berming for snow storage area in order to contain sediment and sweep it in the spring. Provide linear pretreatment feature for spring melt from snow storage area. Consider downstream treatment/infiltration feature adjacent to city dock storage.

Library Lake Watershed Stormwater Improvements and Park Development

Description and Purpose of Activity

The city will continue to support the efforts of the Beaver Dam Lake Management District in the completion of the Library Lake Management Plan.

Library Lake Restoration and Shoreline Restoration

Description and Purpose of Activity

This phase of the Library Lake restoration project includes management activities within the lake itself: aquatic vegetation management, dredging for navigation, dredging to remove sediment at outfalls and restoration of native vegetation along the shoreline.

Library Lake Outlet Restoration

Description and Purpose of Activity

The Library Lake Management Plan was developed in order to reduce stormwater runoff volume, treat runoff to remove pollutants, improve navigation and native habitat, and provide an accessible public amenity. The purpose of this initiative is to implement the Phase 3 recommendations of the Library Lake Management Plan.

This project will reinstate the Library Lake outlet under Highway 63/48 ([Error! Reference source not found.](#)) to restore the lake's natural hydrology.

Pollution Prevention Plans for Industrial Sites

Description and Purpose of Program

The City will work with landowners and property managers for the industrial properties within the city to develop pollution prevention plans. Pollution prevention plans will reduce the exposure of stormwater to pollutant sources that could be detrimental to lake quality.

Collingwood Lake Monitoring

Description and Purpose of Activity

Collingwood Lake has not been included in former water quality planning and management. Water quality modeling conducted in development of this plan identified drainage areas that contribute relatively high loads of total phosphorus to Collingwood Lake. The purpose of this initiative is to identify the state of Collingwood Lake's water quality and to study its watershed to develop water quality improvement projects.

Water quality monitoring will entail sampling for total phosphorus, chlorophyll-a, and Secchi depth twice a month from June through September for three consecutive years. An aquatic plant survey should be completed on a regular basis. Data will be analyzed to identify the trophic status of the lake and to identify management needs such as aquatic invasive species management.

Collingwood Lake Stormwater Management Facility Identification and Siting

Description and Purpose of Activity

Collingwood Lake has not been included in former water quality monitoring or evaluation. However, the water quality modeling for this study identified the estimated loading to Collingwood Lake from its contributing watershed. The watershed contributions are not the highest in the city but are mid-level contributions in Tier 2 and 3. The incorporation of stormwater management facilities to these subwatersheds would be expected to benefit the water quality of Collingwood Lake. The purpose of this initiative is to study the lake and its high-contributing watersheds and identify specific water quality projects. The projects identified in this evaluation will be added to this plan for construction and implementation.

Cemetery Bay Watershed Stormwater Management Facility Identification and Siting

Description and Purpose of Program

Cemetery Bay of Beaver Dam Lake East was found in 2007 to have poor water quality varying from eutrophic to hypereutrophic conditions according to the Beaver Dam Lake Water Quality Study (Barr, 2008). Water quality has deteriorated since 1994. In addition, water quality modeling conducted in development of this plan identified drainage areas that contribute relatively high loads of total phosphorus to Cemetery Bay. The purpose of this initiative is to study these high loading subwatersheds to identify specific water quality improvement projects for Cemetery Bay.

Rabbit Island Bay Watershed Stormwater Management Facility Identification and Siting

Description and Purpose of Activity

Rabbit Island Bay of Beaver Dam Lake West was found in 2007 to have reasonably good water quality conditions varying from mesotrophic to eutrophic according to the Beaver Dam Lake Water Quality Study, but water quality has declined since 1994 (Barr, 2008). Water quality modeling conducted in development of this plan identified drainage areas that contribute relatively high loads of total phosphorus to Rabbit Island Bay. The purpose of this initiative is to study the bay and its high-contributing watersheds and identify specific water quality improvement projects that will improve the water quality concerns for the Rabbit Island Bay Watershed. The projects identified in this evaluation will be added to this plan for construction and implementation.

Norwegian Bay Watershed Stormwater Management Facility Identification and Siting

Description and Purpose of Program

Norwegian Bay of Beaver Dam Lake East was found in 2007 to have poor water quality conditions according to the Beaver Dam Lake Water Quality Study (Barr, 2008). Water quality has deteriorated since 1994. In addition, water quality modeling conducted in development of this plan identified four drainage areas that contribute relatively high loads of total phosphorus to Norwegian Bay. The purpose of this initiative is to study the bay and its high-contributing watersheds and identify specific water quality improvement projects that will improve the water quality for Norwegian Bay. The projects identified in this evaluation will be added to this plan for construction and implementation.

Landlocked Basin Stormwater Management Facility Identification and Siting

Description and Purpose of Activity

The Landlocked Basin discharges to Library Lake infrequently (only under back-to-back 100-year 24-hour storm events). Water quality modeling conducted during development of this plan indicates relatively high phosphorus loading from some drainage areas within the Landlocked Basin. The receiving wetland is likely to be adversely affected by high phosphorus levels and high runoff rates from upstream land uses and land use changes under future development. The purpose of this initiative is to study the Landlocked Basins for flooding issues and for detrimental effects to surface water resources within the Landlocked Basin. This study will ultimately yield land use change guidance and stormwater management plans for future development.

Vermillion River Watershed (Cumberland Municipal Airport) Stormwater Management Facility Identification and Siting

Description and Purpose of Activity

Cumberland Municipal Airport (110 acres in size) is southeast of the contiguous boundaries of the city of Cumberland and discharges to the Vermillion River. Water quality modeling conducted during development of this plan indicates relatively high phosphorus loading. The purpose of this initiative is to reduce pollutant loading to Vermillion River. The projects identified in this evaluation will be added to this plan for construction and implementation.

Beaver Dam Lake West Watershed Stormwater Management Plan for Future Development

Description and Purpose of Activity

Beaver Dam Lake West was found in 2007 to have excellent water quality conditions according to the Beaver Dam Lake Water Quality Study (Barr, 2008). Overall water quality has been consistent since 1992. Water quality modeling conducted in development of this plan found that areas draining to Beaver Dam Lake West have relatively low total phosphorus loading. The purpose of this initiative is to protect Beaver Dam Lake West through study of the lake and its watershed and, ultimately, development of water quality improvement projects. A study of the Beaver Dam Lake West Drainage Area will enable the city to identify sources of water quality pollution based on existing conditions and in anticipation of future land-use conditions. The study will ultimately yield a planning-level implementation plan for BMPs based on expected future land use conditions.

THIS PAGE LEFT BLANK INTENTIONALLY

Implementation Plan Table

10 Year Plan: annual schedule breakdown	2023	2024	2025	2026	2027	2028-2033
PROGRAMS						
Site Plan Review Permitting & Enforcement	X	X	X	X	X	X
Stormwater Infrastructure Inspection & Maintenance	X	X	X	X	X	X
Pollution Prevention on City Properties	X	X	X	X	X	X
Aquatic Invasive Species Management	X	X	X	X	X	X
Monitoring and Data Assessment	X	X	X	X	X	X
Education & Outreach	X	X	X	X	X	X
Geographic Information System (Support for Stormwater Utility)	X	X	X	X	X	X
PROJECTS						
Ordinance Development & Revisions	X	X				
Storm Sewer Outfall Dredging Policy	X					
Riprap at Storm Sewer Outlets	X	X	X			
Pipe Maintenance	X					
Stormwater Infrastructure Improvements						
<i>Downtown Infrastructure Investigation</i>	X	X				
<i>Catch Basin Stormwater Treatment</i>				X		
<i>Winter Maintenance Materials Management</i>		X				
Library Lake Watershed Stormwater Improvements and Park Development	X	X	X	X	X	
Library Lake Restoration and Shoreline Restoration	X	X	X			
Library Lake Outlet Restoration						X
Pollution Prevention Plans for Industrial Sites	X	X	X	X	X	X
Collingwood Lake Monitoring				X		
Collingwood Lake Stormwater Management Facility Identification and Siting					X	
Cemetery Bay Watershed Stormwater Management Facility Identification and Siting					X	X
Rabbit Island Bay Watershed Stormwater Management Facility						X

10 Year Plan: annual schedule breakdown	2023	2024	2025	2026	2027	2028-2033
Identification and Siting						
Norwegian Bay Watershed Stormwater Management Facility Identification and Siting						X
Landlocked Basin Stormwater Management Facility Identification and Siting						X
Vermillion River Watershed (Cumberland Municipal Airport) Stormwater Management Facility Identification and Siting						X
Beaver Dam Lake West Watershed Stormwater Management Plan for Future Development						X
TOTAL NUMBER OF PROJECTS	8	7	4	4	4	8

11.FINANCING OPTIONS

There are many mechanisms for generating funds for stormwater management operation, maintenance, new initiatives, and capital expenditures. Funds may be appropriated from general revenues, bond sales, special-purpose sales taxes or other existing funding enterprises. Revenue can be generated from user fees such as charges, assessments, fines, or special fees to customers (e.g. plan review and inspection fees). Resources could include federal and state grants and loans, maintenance performed by homeowners' associations or private landowners, developer-contributed capital facilities or easement dedications. (NAFSMA, 2006). The city of Cumberland may be best suited for implementation of some combination of the following funding strategies: stormwater utility, area charges, municipal bonding, grants, and loans. For all funding strategies, the key to a successful program is a clear identification of the needs for stormwater management funding and the authority, capability and vision to meet them. The stormwater management problems must be identified and publicized in order to gain public participation and support in order to gain buy-in for generating funding.

Stormwater Utility

The City of Cumberland Adopted a Stormwater Utility in February 2013 but has not been enacted.

The fees collected through this utility would be used to acquire, construct, lease, own, operate, maintain, extend, expand, replace, clean, dredge, repair, manage and finance the city's storm system which can include facilities such as surface and underground drainage facilities, sewers, watercourses, retaining walls, ponds, basins, streets, roads, ditches and such other facilities as will support a storm water management system.

Special Assessments

Area Charges (and Other Fees)

Up-front area charges (also called impact fees) could be applied to new development. Up-front area charges are intended to meet the city's onetime expenses and facility maintenance costs during the critical establishment phase of stormwater practices (BMPs, ponds, regional infiltration basins). Long-term operation and maintenance for the upkeep of stormwater management facilities would be funded through a different mechanism (e.g. stormwater utility). The area charge is a one-time up-front fee that could be charged on a per acre basis. In the case where runoff requirements must be addressed internally at the site level, no differentiation would need to be made between high- and low-density developments. Although a higher density development would produce a greater percentage of stormwater runoff or pollution, the development would provide treatment on-site, requiring greater controls to meet stormwater standards and ultimately effecting the same off-site change in runoff on a per-acre basis. This creates a 'pay as you go' system for development with the treatment needed locally commensurate with the impact created. This approach also provides incentive for the development to reduce its impact through its site design. In-lieu of construction fees are related, but these fees are usually a substitute for requiring on-site storage and treatment if, for example, storage treatment is not feasible on-site. Stormwater rules may or may not consider infeasibility of on-site construction an option. In-lieu of construction fees do not fund maintenance. Finally, capitalization recovery fees are established to recover a significant portion of prior public investment in infrastructure capacity which was installed prior to development in order to accommodate future development. The fees apply to developers who make use of the

provisional capacity at the time that they develop. These fees may not be specifically authorized in legislation but could be incorporated into a stormwater utility fee rate structure on a case-by-case basis.

Municipal Bonding

Municipal bonding is commonly used to fund major capital expenditures and has also been used to fund stormwater utility development costs. Debt funding can also be conducted through intergovernmental loans, warrants and other mechanisms. This funding mechanism enables more immediate action which can be especially important for flood protection projects. If not otherwise specified by the bond, debt service of bonds can be derived from, among others, general revenues, service fees such as a stormwater utility, or special assessments of properties served by the bond fund. Debt funding, however, incurs an interest expense which ultimately increases the cost of the project(s). (NAFSMA, 2006)

Revenue bonding and general obligation bonding typically differ based on the source of support and the interest expense. General obligation bonds are funded by all revenues and resources of the issuing agency. Revenue bonding is supported only by specific revenues (e.g. service fees or assessments) and often imposes higher interest rates and requires coverage to reduce the risk of non-payment. The NAFSMA indicates that the bond market recognizes stability in stormwater utility fee income and prices stormwater revenue bonds favorably (NAFSMA, 2006). There are also combination scenarios where elements of revenue and general obligation bonds are combined (called ‘double-barreling’ of bonds).

Grants

The city of Cumberland is eligible for many grants and some loans offered through the state of Wisconsin, federal agencies, and non-profits. Table 11 summarizes the available grants for the city pertaining to water resources and infrastructure improvement. Other loan opportunities may be available through state and federal agencies.

Table 11. Potential Grant Sources

Grant Program	Entity	Goals/Objectives	Funding Rates and Limits
Surface Water Restoration and Management Grants	Wisconsin Department of Natural Resources (W-DNR)	Implement projects identified in a management plan to improve water quality in a Wisconsin water body. Specific grants include: Surface Water Restoration, Management Plan Implementation, Ordinance Development, Land Easement & Acquisition, and Wetland Restoration.	Up to 75% to construct stormwater BMPs, maximum of \$200,000 (see https://dnr.wisconsin.gov/aid/SurfaceWater.html for more information on funding of specific grants)
AIS Prevention and Management Grants	W-DNR	Identify and reduce the spread of aquatic invasive species (AIS) in Wisconsin water bodies. Specific grants include: Clean Boats, Clean Waters; AIS Prevention, AIS Early Detection and Response, and AIS population management.	75% of project costs (total amount varies based on which specific grant is requested)
Education and Planning Grants	W-DNR	Reach people with information on how surface waters work, their importance, and how we can protect them. Also for planning work to develop goals for future management actions for a water body. Specific grants include: Surface Water Planning, Surface Water Education, and Comprehensive Management Planning.	75% of project costs (up to \$50,000 annually)
Community Development Block Grant Planning Grant Program	Wisconsin Department of Commerce (W-DOC)	Funds support community efforts to address improving community opportunities and vitality. Example projects include: comprehensive plans, community development plans, small area and neighborhood plans.	Maximum of \$50,000 (50% match requirement)
Community Development Block Grant for Public Facilities	W-DOC	Funds help support infrastructure and facilities projects for communities. Example projects include: improvements to streets, drainage systems, sewer and water systems, sidewalks, and community centers.	Maximum of \$1,000,000 (there is a matching requirement)
North American Wetland Conservation Act*	U.S. Fish & Wildlife Service (USFWS)	Long-term enhancement of wetlands for the benefit of wetlands-associated migratory birds and other wildlife.	Maximum of \$100,000 (50% match requirement)
Various Grants	National Fish and Wildlife Foundation	Various grants available for conservation efforts.	See: https://www.nfwf.org/programs
Municipal Flood Control Grants	W-DNR	Municipal flood control management to protect life, health and property from flood damages	Up to 50% of eligible project costs

Grant Program	Entity	Goals/Objectives	Funding Rates and Limits
Acquisition and Development of Local Parks (Stewardship)	W-DNR	Expand opportunities for nature-based outdoor recreation.	Up to 50% of eligible project costs
Acquisition Development Rights (Stewardship)	W-DNR	Protect natural, agricultural, or forestry values that would enhance nature based outdoor recreation	Up to 50% of eligible project costs
Land and Water Conservation Fund	W-DNR	Create parks and open spaces, protect wilderness, wetlands, and refuges, preserve wildlife habitat, and enhance recreational opportunities	Up to 50% of eligible project costs
Recreational Trails Program	W-DNR	Assist local communities and trail groups in the development, maintenance, or rehabilitation of recreational trails	Up to 80% of eligible project costs
Local Bridge Improvement Assistance	Wisconsin Department of Transportation (W-DOT)	To help rehabilitate and replace the most seriously deficient existing local bridges on Wisconsin's local highway systems	Up to 80% of eligible project costs (20% match required)

* The City itself may not be eligible, but a community group could be

12. REFERENCES

- Barr Engineering Company. April 2008. 2007 Beaver Dam Lake Water Quality Study. Prepared for Beaver Dam Lake Management District.
- Barr Engineering Company. February 2009. 2008 Beaver Dam Lake Report and Amended Aquatic Plant Management Plan. Prepared for Beaver Dam Lake Management District.
- Barr Engineering Company. February 2021. Beaver Dam Lake Aquatic Plant Management Plan. Prepared for Beaver Dam Lake Management District.
- Benike, H. and Disrude, M. April 2008. Beaver Dam Lake Fisheries Survey, Barron County, Wisconsin, 2005-2007, MWBIC: (2081200). Wisconsin Department of Natural Resources, Northern Region-Barron.
- Beretta, S.C., and J.J. Sansalone. Quantifying Nutrient Loads Associated with Urban Particulate Matter (PM), and Biogenic/Litter Recovery Through Current MS4 Source Control and Maintenance Practices. Gainesville, Florida: University of Florida, College of Engineering, May 31, 2011.
- Cappiella, K., T. Schueler, and T. Wright. 2005. Urban Watershed Forestry Manual Part 2: Conserving and Planting Trees at Development Sites. Prepared for: USDA Forest Service. Center for Watershed Protection. Ellicott City, MD.
- Emmons & Olivier Resources, Inc. September 2022. Library Lake Restoration and Management Plan (Updated). Prepared for the Beaver Dam Lake Management District.
- Gulliver, J.S., A.J. Erickson, and P.T. Weiss (editors). 2010. *Stormwater Treatment: Assessment and Maintenance.* University of Minnesota, St. Anthony Falls Laboratory. Minneapolis, MN. <http://stormwaterbook.safl.umn.edu/>
- Kalinosky, Paula. Quantifying Solids and Nutrient Recovered Through Street Sweeping in a Suburban Watershed. University of Minnesota, 2015.
- Minnesota Pollution Control Agency. 2005-2022. Minnesota Stormwater Manual. https://stormwater.pca.state.mn.us/index.php?title=Main_Page Accessed: December 20, 2022.
- MPCA. Stormwater Management: Low-Impact Development and Green Infrastructure. Minnesota Pollution Control Agency, November 16, 2009. [Green Stormwater Infrastructure \(GSI\) and sustainable stormwater management - Minnesota Stormwater Manual \(state.mn.us\)](https://www.pca.state.mn.us/gsi)
- National Association of Flood and Stormwater Management Agencies (NAFSMA). 2006. Guidance for Municipal Stormwater Funding. Funded by the U.S. Environmental Protection Agency.
- Schueler, T. 1995. Site Planning for Urban Stream Protection. Center for Watershed Protection. Ellicott City, MD. http://www.cwp.org/Resource_Library/Better_Site_Design/

Seattle Public Utilities. Seattle Street Sweeping Pilot Study, Monitoring Report. Seattle, WA: Seattle Public Utilities in association with Herrera Environmental Consultants, 2009.

Shaw, D. and R. Schmidt, 2003. Plants for Stormwater Design - Species Selection for the Upper Midwest. Edited by S. Brungardt, Designed by R. Harrison, Minnesota Pollution Control Agency, St. Paul, MN.

U.S. Environmental Protection Agency (USEPA). Methodology for Analysis of Detention Basins for Control of Urban Runoff Quality. Nonpoint Source Branch, Washington, EPA 440/5-87-001, September 1986.

Walker, W.W. Program for Predicting Polluting Particle Passage thru Pits, Puddles and Ponds (P8), Version 3.4. Release Date: October 30, 2007. Support from: United States Environmental Protection Agency, Wisconsin Department of Natural Resources, Minnesota Pollution Control Agency.

West Central Wisconsin Regional Planning. February 6, 2018. City of Cumberland Comprehensive Plan 2017-2037. Prepared for the City of Cumberland.

Wisconsin Department of Natural Resources (DNR). Consensus-Based Sediment Quality Guidelines: Recommendations for Use & Application, Interim Guidance. Developed by the Contaminated Sediment Standing Team, December 2003. Report No. WT-732 2003.

Zielinski, J., 2001. The Benefits of Better Site Design in Residential Subdivisions. Watershed Protection Techniques, 3(2):633-646. Center for Watershed Protection. Ellicott City, MD

APPENDIX A. STORMWATER BEST MANAGEMENT PRACTICES

Better Site Design (BSD)

Better site design (BSD) incorporates non-structural and natural approaches to new and redevelopment projects to reduce effects of stormwater runoff on watersheds by conserving natural areas, reducing impervious cover and better integrating stormwater treatment. BSD seeks to preserve natural drainage features including, but not limited to, contours, gully's/drainageways, wetlands, streams, groundwater dependent natural resources, recharge areas, forests, tree stands and sensitive ecosystems. BSD can be applied at the regional, development or site level, to protect natural drainage and ecological features by siting buildings and roads non-uniformly across the site. When applied early in the design and layout process, BSD techniques can sharply reduce stormwater runoff and pollutants, and also reduce the size and cost of both the stormwater conveyance system and stormwater management practices (Center for Watershed Protection, 1998a). The following are elements of Better Site Design for stormwater management:

Amended Soils

Land development including landscaping practices damage soil structure and function by removing or compacting topsoil. These practices decrease infiltration and increase erosion thereby impairing fish habitat and increasing the need for downstream stormwater management. These practices also create chemically dependent landscapes which are difficult and expensive to maintain and contribute to polluted runoff. Soil compaction also reduces the water retention capacity of soil which requires additional irrigation and increased public water supply demand.

Along with ensuring that topsoil is not compacted, it is recommended that topsoil be amended with compost. Compost, an organic material, absorbs and infiltrates rainwater, reduces flooding and soil erosion and filters out pollutants typically associated with stormwater runoff. Compost also stores water and nutrients for plants to use during drought conditions, promoting healthy plants and better-looking lawns that require less irrigation, pesticides and fertilizers. In addition, healthy amended soils require less irrigation and reduce municipal water demand.

Native Landscaping

Traditionally, landscaping and stormwater management have been treated separately in site planning. In recent years, engineers and landscape architects have discovered that integrating stormwater into landscaping features can improve the function and quality of both. The basic concept is to adjust the planting area to accept stormwater runoff from adjacent impervious areas and utilize plant species adapted to the modified runoff regime.

Table 12: Environmental factors to consider when integrating stormwater and landscaping.

Factor	Problem Addressed
Duration and depth of inundation	Increased duration and depth of water changes the physical and chemical environment in ways that may favor invasive plants
Frequency of inundation	Increased frequency of inundation can carry increased levels of pollutants and toxins
Management of moisture during dry	Soil compaction can affect plant species success at a site and the ability of the soil to infiltrate stormwater efficiently

weather	
Sediment loading	Susceptibility to erosion and sedimentation from stormwater affects placement of stormwater management BMP as well as selection of plant material
Salt exposure	Browsers (deer and beaver) may be attracted by increased levels of salt in areas that treat roadway and parking lot runoff
Nutrient loading	Increased slopes increase ability to transport nutrients in stormwater

Native plants are the ideal choice as their roots grow 4'-15' deep, reinforcing soils and improving infiltration capacity. In contrast, turfgrass roots only grow 2-6" deep and excellent guidance on how to match plant species to stormwater conditions can be found in the MPCA publication *Plants for Stormwater Design: Species Selection for the Upper Midwest* (Shaw and Schmidt, 2003) and in *Cappiella et al. (2005)*.

A landscaped area may provide full or partial stormwater treatment, depending on site conditions. An excellent example of the use of landscaping for full stormwater treatment is bioretention as outlined within the Structural BMPs section. In other cases, landscaping can provide supplemental treatment such as green rooftops and stormwater planters. Even small areas of impervious cover should be directed into landscaping areas since stormwater or melt water help to reduce irrigation needs.

Reducing Impervious Surfaces

Impervious areas such as roads and parking pavement, building surfaces, and walkways/driveways significantly increase stormwater runoff volumes. Impervious surfaces also facilitate the wash-off and transport of pollutants like oil, grease and sediment into downstream rivers, lakes, and wetlands. Reducing imperviousness reduces stormwater discharge which thereby reduces flooding, erosion, and pollutant loading. Reduced runoff can also reduce the size and cost of stormwater infrastructure. Increased greenspace can facilitate recreational and community activities that enhance the quality of life of residents/employees.



Figure 9: Impervious cover removal in backyard (<https://www.riversmarthomes.org/isr>)

Managing the extent of impervious area of buildings, roads and parking pavements occurs through the site planning and design process. Example methods to reduce imperviousness include but are not limited to, narrower road sections, alternative road layouts, reduced application of sidewalks and on-street

parking, cul-de-sac design, parking lot design, house setbacks, structure/building impervious area limits and driveway designs.



Figure 10: Trees and Vegetation Planted in the Landscaped Island of a Cul-de-sac (left) and a Loop Road (right) (Minnesota Pollution Control Agency 2013)

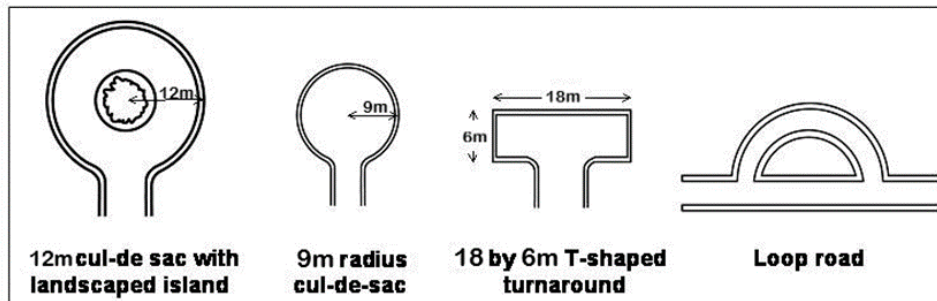

Figure 11: Turnaround Options for Residential Streets (adapted from: Schueler 1995)

Impervious areas can also be effectively removed by routing runoff flow to an area that will absorb the water, such as a yard, swale or bioretention area. This includes disconnecting downspouts and ensuring that new building standards include requirements for disconnection.

Natural Area Protection

Natural area conservation protects natural resources and environmental features that help maintain the pre-development hydrology of a site by reducing runoff and promoting infiltration. Examples include any undisturbed native vegetation preserved at the development site, such as forests, open spaces, and riparian areas; ridge tops and steep slopes, and stream, wetland and shoreline buffers. Designers should also place a particular priority on preserving natural drainage pathways, intermittent and perennial streams, and floodplains and their associated wetlands. Buildings and roads should be aligned to follow the natural topography so as to avoid unnecessary disturbance of vegetation, soils and natural drainage ways.

Open Space Design

Open space design is a form of residential development that concentrates development in a compact area of the site to allow for greater conservation of natural areas. This form of development may also be called cluster design, conservation design, or low impact development (LID) (Figure 4). A mixed-use approach that integrates usable grassed park space with a trail system among restored native ecosystems

and preserved drainageways and wetlands can be a very effective approach. Shared driveways and utilities are one example of impervious surface reduction that can facilitate the preservation of open space.

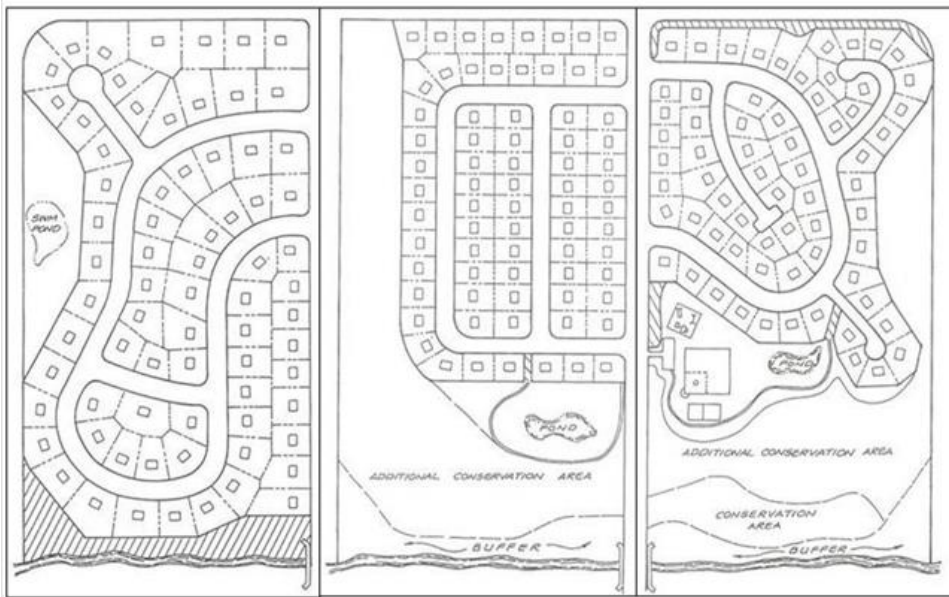

Figure 12: A conventional subdivision (left - 72 lots) with alternative layouts (center - 72 lots; right - 66 lots) implementing open space design.

Image Source: Schueler (1995)

Vegetated Buffers

Vegetated buffers work by prohibiting stormwater runoff from flowing directly into a water body. The vegetation catches pollutants carried by stormwater, decreases the rate of flow and volume of runoff, and stabilizes the soil on the shoreline or bank, lessening erosion caused by runoff. For lakeside properties a buffer can also keep harmful pet waste and fertilizers from entering the lake while providing pollinator habitat and improving aesthetics through native plants.

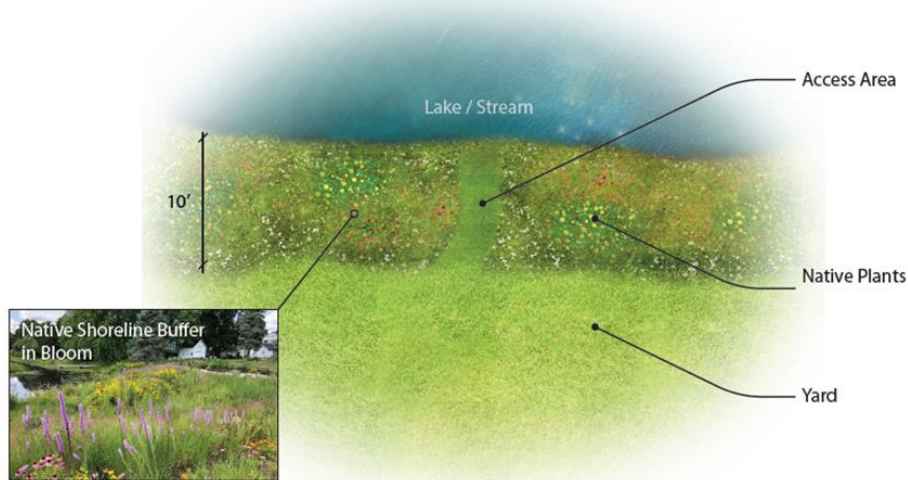

Figure 13: Shoreline buffer (EOR)

Structural BMPs

The Structural BMPs outlined within this section can play a huge role in effective stormwater management at the City of Cumberland and can be implemented as stand-alone features or in series to multiply the benefits, known as the treatment train approach.

For this section the BMPs have been organized by the methods in which they achieve the stormwater management goals of reducing overall runoff, reducing peak flows of runoff, moderating water temperature, groundwater recharge, and improving water quality prior to release to a local waterbody. BMPs can achieve those stormwater goals through pre-treatment and filtration to improve water quality, and infiltration, detention, and evaporation to reduce runoff volumes and encourage infiltration. Many of the BMPs outlined below achieve multiple stormwater goals due to their design.

All structural BMPs that focus on infiltration, require proper siting and sizing. BMPs are sited downslope of impervious surfaces in permeable soils and in HSG A (sand/loamy sand) and B (loam/silty sand) soils wherever feasible to maximize stormwater infiltration (refer to *Soils* on page 7 and Figure 4. Hydrologic Soil Groups.). Soil borings are necessary in the locations of proposed BMPs to assess the infiltration capacity of the soil as characterized by the hydrologic soil group. Soil boring results guide the selection of BMPs and help to ensure the BMP will function properly. Onsite soil verification during construction enables siting or sizing adjustments in the case of spatial heterogeneity of HSGs. Underdrains facilitate management of water levels during establishment of vegetation and provide operational flexibility.

Pre-treatment & Filtration practices

Improving the quality of the stormwater runoff before it enters the ground, or adjacent waterbody is one of the most important stormwater management goals and can be achieved through the introduction of pre-treatment and filtration practices either on their own, or as part of the treatment train approach.

Pre-treatment is also an essential design element for structural BMPs to facilitate their long-term effectiveness and ensure that they operate as designed. This is achieved by removing sediment and pollutants from runoff prior to discharge into the infiltration practices which reduces the risk of the BMP media clogging and failing, which also makes the practices easier and more affordable to maintain. There are a wide range of pre-treatment and filtration practices which include settling devices, screens, and vegetated filters.

Settling Devices: These devices are often proprietary, with the main method of pollutant removal through the settling of coarse materials. They have many names including water quality inlets, flow-through devices, hydrodynamic separators, grit chambers, forebays, sump manholes, etc. Typically, these devices only capture coarse sediment and provide little to no removal of pollutants such as nutrients or metals. They do not provide volume control or flow control.



Pre-treatment chamber



Oil grit separator



Proprietary systems – Rain Guardian



Custom Concrete Forebays



Custom Concrete Forebays

Figure 14: Settling Devices

Screens: Screens are those devices where the primary method of pollutant removal is through screening with a perforated plate or mesh screen to stop sediment, trash, debris, and organic material as water flows through. Screens do not provide volume control or flow control and can be incorporated into a settling device or used on their own.

Vegetated Filter Strips: These areas filter the water through vegetation and soil media to remove pollutants. For them to be effective water flow must be shallow and distributed to reduce flow velocity and allow particles to settle.



Figure 15: Vegetated Filter Strip

Infiltration, Evaporation and Detention Practices

To achieve the stormwater goals of reduced runoff and peak flows, groundwater recharge and improved water quality, this section outlines BMPs that are designed to encourage infiltration, evaporation, and detention of stormwater. Pre-treatment is recommended prior to directing any stormwater into a BMP that infiltrates, though practices that include vegetation often do provide water quality treatment as well.

Bioretention practices

Bioretention is a water quality and water quantity stormwater treatment practice that utilizes the chemical, biological and physical properties of soils, microbes, and plants for infiltrating and/or filtering stormwater runoff. Bioretention practices will always have plants. Stormwater directed to a practice can either infiltrate into the underlying soil, discharge through an underdrain, or be stored within the media and eventually taken up by the vegetation.



Figure 16: Bioretention basin diagram

As Bioretention facilities are designed for filtration as well as infiltration they can be designed to capture the first flush of runoff with excess water directed through an overflow outlet to an existing storm sewer. Bioretention facilities can be designed to fit a variety of applications making them a very versatile and widely adopted stormwater practice, especially in site retrofit project.

Typical applications of bioretention include:

- **Parking lot islands and margins** can be added at design or as retrofit project. Pre-treatment is recommended to minimize groundwater contamination.
- **Road right-of-way or cul-de-sacs** can be added at design or as a retrofit project. Pre-treatment is recommended to minimize groundwater contamination.
- **Homeowner raingardens** can be built to any shape and size. Pre-treatment is not necessary.

BEST PRACTICE TIP – Groundwater Contamination

Whenever runoff is directed to an infiltration BMP, there is a danger of groundwater contamination by the pollutants being carried in the runoff. Any surface runoff that may contain toxic or highly contaminating material should not be routed to an infiltration practice unless some form of pre-treatment is provided to remove the contaminant.

Permeable Pavements

Permeable Pavements allows the incorporation of essential hardscapes into the new and retrofit developments without increasing stormwater runoff from impervious surfaces. Permeable pavements allow water to pass through the surface and infiltrate into the soil below and can be used for streets, parking lots & laybys, pedestrian paths, and plazas. Permeable pavements come in variety of forms and can be cast in place or pre-cast, with both kinds needing careful maintenance to maintain function including period vacuuming and the avoidance of road sand during winter months.

Permeable asphalt is most often used within parking and street applications and consists of fine and coarse aggregate stone bound by a bituminous-based binder. The amount of fine aggregate is reduced to allow for a larger void space of typically 15 to 20 percent. Pervious asphalt must be constructed in place. The method of cleaning is vacuuming.

Figure 17: Permeable Asphalt





Permeable concrete is a mixture of Portland cement, fly ash, washed gravel, and water. Unlike conventional concrete, permeable concrete usually contains a void content of 15 to 25 percent. Permeable concrete can be cast in place or pre-cast off-site and brought in. The method of cleaning is vacuuming.

Figure 18: Permeable Concrete

Permeable concrete pavers, when installed, form patterns that create openings through which rainfall can infiltrate. These openings, generally 8 to 20 percent of the surface area, are typically filled with pea gravel aggregate.

Figure 19: Permeable Concrete Pavers



Grid systems, sometimes referred to as geocells, consist of flexible plastic or concrete interlocking units that allow for infiltration through large gaps filled with gravel or topsoil planted with turf grass. Empty grids are usually at least 90 percent open space, so void space depends on the fill media. Applicable to extra parking areas at certain times of the year, as well as emergency vehicle access.

Figure 20: Concrete Grid



Infiltration practices

Stormwater infiltration practices capture and temporarily store stormwater to facilitate infiltration into the soil. Infiltration reduces stormwater pollutant discharges to receiving waterbodies, increases groundwater recharge and baseflow in streams, reduces peak flow rates, and reduces thermal impacts of stormwater runoff. Infiltration design variants include the infiltration basin, the infiltration trench or French drain, underground infiltration systems and dry wells. Infiltration practices like trenches and dry wells can often be incorporated into site retrofits as their designs are adaptable and can fit into smaller spaces

Infiltration Basin: Infiltration basins are usually excavated depressions or natural impoundments used to capture, store, and slowly infiltrate stormwater from large catchments. Infiltration basins are not intended to have constant standing water and will include an outlet for the removal of excess water. Infiltration basins can be designed to capture all storm events or just major events. Basins designed for larger events can be created to serve multiple purposes like playing fields for times they are not inundated with water.



Figure 21: Infiltration Basin doubling as recreational space

Infiltration Trenches: Infiltration trenches are shallow trenches filled with stone aggregate that acts as a reservoir and infiltration area for stormwater runoff. Stormwater runoff is often directed to the trench directly from adjacent impervious areas, so they are often found next to roadways or paths and within parking lots. Typically, infiltration trenches are designed for small sites (e.g., five acres or less) but can be applied to larger areas if designed properly. Consideration should be given to the slopes of the contributing drainage area.



Figure 22: Infiltration Trench (MPCA)

Underground infiltration practices: Underground infiltration systems, including pre-manufactured pipes or modular structures, have been developed as alternatives to infiltration basins and trenches for space-limited sites and stormwater retrofit applications. These systems are similar to infiltration basins and trenches in that they are designed to capture, temporarily store and infiltrate the design volume of stormwater over several days. Underground infiltration systems should be installed in areas that are easily accessible to routine and non-routine maintenance. Underground infiltration systems can be constructed with or without modular structures though modular structures substantially increase storage volume. Typical applications for underground infiltration systems include:

- Below parking lots or ball fields
- Retrofits in more densely developed areas



Figure 23: Underground infiltration chambers being installed under a parking lot (EOR)

Vegetated Swales

Swales are a type of stormwater treatment composed of vegetation and a porous subsoil medium. A swale is a long, vegetated depression often used as a water conveyance system which is also designed to infiltrate water and remove sediment and pollutants from runoff using check-dams. A swale, therefore, assists in recharging ground water and managing stormwater runoff quantity and quality and can therefore be classified as a filtration BMP as well. Maintaining a swale upstream of surface waters reduces pollutant impacts from sediment, phosphorus, nitrogen, and high temperature waters.

Vegetated swales are often grassed but can be landscaped to provide an aesthetic appeal and provide natural habitat within an urban setting. Vegetation can range from tall plants and grasses to a short turf grass depending upon the desired application of the swale. Any vegetation used should be water tolerant. Native vegetation is preferred with its ability to uptake water and filter pollutants like phosphorus and sediment. Roots of native vegetation grow deep to stabilize the soil and promote infiltration, and native vegetation does not require irrigation after the first year of establishment.

The following are example applications for vegetated swales:

- Natural drainage on a residential lot
- Along local roads in place of curb and gutter
- Parking lot islands and medians
- Highway medians
- First line of defense upstream of the stormwater system
- Aesthetic amenity at civic, commercial or residential sites
- Low flow conveyance in place of structural conveyance

- Pretreatment prior to discharge to open water or stormwater treatment facilities such as infiltration basins



Figure 24: Swale with Native Landscaping

Level spreaders

Level spreaders are structures that spread flow evenly over the same grade to mediate infiltration within riparian buffers, downslope vegetated filter strips or bioretention practices. This distribution of water also allows for coarse sediments to settle out.



Figure 25: Level Spreader (MPCA)

Rainwater / Stormwater Harvesting & Reuse

Rainwater harvesting and reuse is the practice of collecting runoff from rooftops, parking lots and other surfaces and reuse the water for such things as irrigation of gardens and municipal ballparks, and garden/lawn watering. The end use of the water is often dependent on the source of the water, with rooftop rainwater often being sighted as cleaner and less in need of treatment prior to reuse.

Reuse systems can vary from the residential scale with rain barrels for collection and garden irrigation to the building scale for municipal or commercial with the use of cisterns, either internal or external to the building. Harvested rainwater can be used indoors for non-potable uses such as toilet and urinal flushing when approved and indoor use designs are subject to review by state plumbing code. The effect of rainwater harvesting is volume control, reduced flooding and erosion, and less demand for treated potable water.



Figure 26: Rain barrel for harvesting roof runoff

Green Roofs/ Blue Roofs

Roofs can be some of the largest impervious surfaces on a site and contribute greatly to stormwater runoff volumes. Green roofs reduce or eliminate that runoff by storing water within vegetation then releasing it via evapotranspiration from the plants. Blue roofs (and green roofs in saturated situations or non-growing seasons) slowly release the water from its storage areas to the municipal system via a flow control system which regulates the roof drainage thereby contributes to peak flow reduction. Green

Roofs and Blue Roofs can be retrofitted into some developments and provide additional insulation benefits to a building.



Figure 27: Green Roof on Amery Regional Hospital (EOR)

Stormwater Ponds

Stormwater ponds are constructed basins that receive and hold stormwater runoff. They have been a tool in the stormwater management toolbox for over 30 years and improve water quality through settling and biological uptake and to prevent downstream channel degradation or flood damage through outflow rate reduction and storage. During and following a storm event, runoff is stored above the permanent pool and released at a specified rate through a control structure. The actual stormwater rate control performance of stormwater ponds has been variable at best. However, stormwater ponds can be an effective stormwater management tool for its settling properties. They are typically installed as stand-alone practice or at the end of the treatment train of BMPs, for any stormwater that is not directly infiltrated or directed to an adjacent waterbody

Stormwater Wetlands

Constructed wetland systems are implemented to store and treat runoff by emulating the function of natural wetlands. However, stormwater wetlands are not natural wetlands and natural wetland areas should not be utilized as stormwater wetlands. Stormwater wetlands are similar in design to stormwater ponds and mainly differ by their variety of water depths and that the wetland vegetation is a major element of the overall treatment mechanism as opposed to a supplementary component. They require slightly more surface area than stormwater ponds for the same contributing drainage area and when designed and maintained properly, stormwater wetlands can be a valuable aesthetic feature of a site. Figure 22 illustrates design recommendations for a shallow stormwater wetland.

Stormwater wetlands are widely applicable stormwater practices that provide both water quality treatment and water quantity control. They are typically installed at the end of the treatment train of BMPs, if stormwater is not directly infiltrated or directed to an adjacent waterbody.



Figure 28: Stormwater Wetland in Cumberland (EOR)

Phosphorus Reduction Practices

The following BMP practices are specific to improving water quality through the reduction of phosphorus. Excess phosphorus in the water leads to excessive algae growth and undesirable vegetation, and the depletion of oxygen levels which can kill fish. Along with practices such as this to reduce phosphorus going into the water, a phosphorus fertilizer ban went into effect in 2010, banning the use and sale of any turf fertilizer that is labeled as containing phosphorus or available phosphorus.

Iron Enhanced Sand Filters: These practices are filtration BMPs that focus on improving water quality through the removal of dissolved contaminants, like phosphorus, via the filtration of stormwater through media of sand mixed with iron filings. As the primary treatment mechanisms with this BMP are filtration and chemical binding and not volume reduction or infiltration, there is no need to vegetate the system which could cause adverse effects. This type of BMP is most applicable to urban land use with high perviousness and for moderate loads.



Figure 29: Installation of Iron-Enhanced Sand Filter in Deerwood, MN (EOR)

Programmatic BMPs

Programmatic BMPs include those municipal procedures, programs and practices that work in partnership with Structural BMPs to support stormwater management goals and include municipal ‘housekeeping’ programs, regulations, ordinances, and education programs & training. They are front-end methods that work to manage rainwater at the source, identifying potential pollutants and addressing them before they make their way into runoff, as well as identifying areas and ways for runoff to be reduced.

Programmatic BMPs add to a holistic understanding of stormwater management, or Integrated Stormwater Management, that tries to consider all aspects of how stormwater interacts with the ground surfaces on its way to its destination, either within the groundwater supply or a local water body. Programmatic BMPs seek to understand and consider all elements that affect stormwater that are within a municipalities power to improve.

Programmatic BMPs

Municipal Programs & Standards

- o Street Sweeping Program
- o Erosion & Sediment Control Standards
- o Hazardous Material Storage and Handling Standards
- o Winter Roads Materials Management Standards
- o Fertilizer/Chemical Application Management Standards
- o Rain Barrel Rebate Program
- o Rainwater Harvesting System Standard

Potential Regulations / Ordinance

- o Stormwater Utility
- o Development Requirements

Education & Training

- o Training for City Staff and Contractors
- o Public Education

Municipal Programs & Standards

Street Sweeping Program

Most municipalities sweep paved roads to some extent annually to improve road safety and appearance but is often overlooked as a non-structural practice for achieving reducing sediment load to receiving watercourses. Pollutants collect on surfaces in between storm events as a result of atmospheric deposition, vehicle emissions, winter road maintenance, construction site debris, trash, road wear and tear, and litter from adjacent lawn maintenance (grass clippings). Street sweeping removes this sediment and other debris from the street before they are transported to the storm sewer network and roadside treatment practices. Several recent studies that made use of newer sweeping technologies and advances in stormwater management reported that street sweeping offers a very cost-effective and

efficient means to reduce pollutant loads to storm sewer infrastructure and to downstream waters (Beretta & Sansalone, 2011; Kalinosky, 2015; Seattle Public Utilities, 2009). Additional benefits of street sweeping include reduced clogging and flooding of storm drains, reduced maintenance to downstream stormwater infrastructure, improved safety for pedestrians. Timing, frequency and targeting critical areas greatly influences the effectiveness of sweeping.



Figure 30: Street Sweeping in Residential Neighborhood (EOR)

Erosion & Sediment Control Standards

Erosion and sediment control (ESC) during construction of areas contributing runoff to an LID is essential to the success of these facilities. While the LIDs recommended in this document are resilient and robust in many ways, sediment can quickly overwhelm and render them ineffective, thereby requiring complete reconstruction to regain the critical stormwater functionality. When the soil and vegetation that provide the pollutant removal and water volume reduction functions are clogged by sediment, they are no longer able to reduce runoff volumes or rates and pollutant loadings.

Hazardous Material Storage and Handling Standards

A hazardous material is any biological, chemical, or physical material with properties that make it dangerous or potentially harmful to human health or the environment. Hazardous materials can be released to the environment in a variety of ways. A spill of only one gallon of oil can contaminate one

million gallons of water. Potential hotspots for higher levels of stormwater pollutants and/or risk for spills, leaks or illicit discharges include:

- Equipment storage and maintenance yards
- Incinerators
- Landfills
- Hazardous waste handling and transfer facilities
- Public works yards
- Vehicle storage and maintenance yards

Minimizing or eliminating contact of hazardous materials with stormwater can significantly reduce pollution of downstream waters. Starting with a spill prevention plan provides a framework for city or facility operations and a training tool for personnel. Proper hazardous material handling and storage also contributes to employee health, an organized workplace, and efficient operation. Proper practices include:

- Confine material storage indoors to the greatest extent feasible, and plug or disconnect floor drains that lead to the stormwater system
- Confine outdoor material storage to designated areas that are covered, away from high traffic areas, outside of drainage pathways, and on impervious surfaces
- Prevent run-on of stormwater into fueling areas using diversion dikes, berms, curbing, surface grading or other measures or use catch basin inserts to prevent discharge into storm drains
- Avoid loading/unloading materials in the rain and/or provide cover for the activity
- When conducting vehicle and equipment maintenance use drip pans, drain boards, and drying racks to direct drips back to a fluid holding tank for reuse or proper disposal

Winter Roads Materials Management Standards

Chloride and sand accumulate in surface and groundwaters due to stormwater runoff from road salt storage piles, areas of excessive application, or simply from years of repeated application. Chloride in road salt and road salt additives (e.g., ferrocyanide for anti-caking) can create toxic conditions for fish, insects, and vegetation. Proper winter road materials storage, handling, and application reduce the risk of downstream water resources pollution and can reduce die-off of exposed vegetation, fish, and other aquatic organisms.

A municipal sand/salt management plan is a commitment to implementing BMPs while fulfilling a community's obligation to provide safe, efficient, and cost-effective roads. The plan should identify BMPs (e.g., securely cover storage piles, calibrate applicator equipment) to reduce the negative environmental impacts of sand and road salt. The plan should apply to all winter maintenance personnel including staff and contractors. Training of staff and contractors should accompany all sand and salt management policies.

A snow management plan identifies the city's methods for managing the accumulation, removal, and potential collection of snow so that procedures are in place for both during and after a snowfall event. This plan should not only address city operations, but also examine how commercial entities are conducting their operations. Snow storage areas should be on paved bermed surfaces if sand is used; this allows the area to be swept after snowmelt and the sand to be contained during runoff. Runoff should be pretreated prior to discharge to receiving stormwater facilities or waterbodies. If salt is used, storage should be on pervious surfaces to prevent direct discharge to surface waters, but storage should be

outside of stormwater treatment areas in order to prevent clogging from sediment and allow for runoff capacity during snowmelt.

Fertilizer/Chemical Application Management Standards

Fertilizers, herbicides, and insecticides have various ecological effects, toxicity, and chemical fate and transport based on the product's chemical components. Depending on the chemicals' characteristics, they can have unintended harmful effects on terrestrial and aquatic plants and animals, and can end up in our soil, water, and air through conveyance by stormwater.

Nitrates from fertilizers can migrate through the soil profile and contaminate ground water supplies beyond safe drinking water levels. Phosphorus from fertilizers contributes to eutrophication of surface water bodies that depletes oxygen levels and can lead to fish kills. Which is why a statewide phosphorus fertilizer ban went into effect in 2010 (2009 Wisconsin Act 9), banning the use and sale of any turf fertilizer that is labeled as containing phosphorus or available phosphorus.

Programs designed to manage and minimize chemical application typically include a combination of the elements identified below. The following BMPs and chemical alternatives can provide the content for training programs and public education materials:

- Integrated Pest Management (IPM): employs mechanical, biological, cultural, and/or chemical mechanisms as determined by a thorough evaluation of the conditions rather than addressing every condition with chemicals.
- Chemical preparation and handling BMPs to select lower toxicity products, reduce spills, and provide secure containment.
- Chemical application BMPs: manages application rates, application sites (not on bare soils or near surface waters) and weather (no application when windy or when rain is forecasted).

Rain Barrel Rebate Program

Rain Barrels not only help to conserve drinking water during summer months but also encourage the disconnection of downspouts, directing stormwater away from municipal systems and helping to increase system capacity. Many cities offer rebates on purchases of residential rain barrels or host sale events themselves. With any event or incentive program, education and outreach is needed to ensure that the barrels are used as intended and people understand why the City is offering them.

Rainwater Harvesting Systems Standard

Rainwater harvest and reuse has grown from the common residential scale application of rain barrels or cisterns to now include regional and large-scale reuse through stored rainwater (and stormwater) within municipal stormwater ponds, dedicated underground storage facilities and integrated cisterns within buildings.

To support this broader reuse the ICC has introduced a standard for '*Rainwater Harvesting Systems*' (ICC 805-2018) to make it easier for jurisdictions to accept and approve rainwater harvesting systems on a much wider scale than previously been possible. The standard provides a framework for both designers and code officials to confidently implement systems that meet the intent of the building, plumbing, health and even fire codes. This standard applies to both roofwater and stormwater reuse for

non-potable and potable application for single-family, multi-family and non-residential buildings. The following uses are discussed within this standard:

Table 13: Rainwater / Stormwater Uses

Non-potable Uses	Potable Uses
Irrigation	Human consumption
Fire Protection	Oral Care
Toilet /Urinal flushing	Food preparation
Hose Bibs	Dishwashing
Vehicle Washing	Bathing
Decorative Fountains	Splash Pads and Swimming Pools

Development Requirements

An important component of any stormwater management program is the alignment of the City’s development requirements to those that will reduce runoff, improve water quality, and encourage infiltration. Development requirements are integrated within subdivision ordinances, zoning regulations, parking and street standards, engineering standards and other local ordinances that regulate development. The recommendations below mainly align with the practice of Better Site Design and seek to take those practices from a *recommendation* to a *requirement* in new or retrofit development.

Impervious cover limit requirements – These requirements place limits on percentage of cover on a new development that can be impervious. This seeks to ensure that areas for natural infiltration are maintained and that alternatives to impervious surfaces are explored. This requirement would vary by development type and is related to Open Space Design as outlined above.

Downspout disconnection requirements – This requirement would require all new development and retrofits to disconnect downspouts into impervious surfaces where possible. This would ensure that roofwater was managed on site and not directed to the municipal system.

Tree retention requirements – This requirement is most often applicable to retrofits and large development blocks where the design of the site is more flexible. It would require that trees (any trees or specific targeted trees) over a certain size be retained on site. This would encourage areas of natural infiltration that impervious surfaces can be directed to.

Minimum soil volumes requirement – This requirement is for new developments and would require the minimum depth, generally 4-6 inches, of soil to be replaced after construction is completed. Soils are the foundation for successful planting, and the water holding capacity of soils can significantly reduce the volume of runoff from a site. In addition to successful plant growth, soils can be engineered to improve water holding capacity through the addition of amendments like compost.

Buffers – This requirement could apply to new and retrofit developments to include minimum size buffers along waterbodies and watercourses. The buffer would act as filter to sediment and other pollutants running off the site as well encourage infiltration and restoration of baseflow for watercourse.

Volume control requirement – While other practices may address stormwater quality and rate control, limiting increased volumes of runoff from development and redevelopment is the most effective way to reduce the cumulative impacts on downstream water resources.

The volume control requirement of the city should be based primarily on the local geology/soils, existing and planned land use, stormwater goals and stakeholder interests. Attaining a balance among these sometimes-competing interests will determine what volume control target is feasible.

Volume control requirements generally fall into two categories: flat target and pre-to-post targets. Flat targets are typically expressed as the volume of runoff generated by a certain rainfall depth, typically 0.5- or 1.0-inch. These targets are usually applied only to impervious surfaces, either net additional impervious or total impervious. Pre-to-post targets require modeling of existing runoff volumes and hold post-development runoff volumes to existing conditions for a return frequency rainfall event, typically the 1- or 2-year storm event. In other words, pre-to-post standards restrict the volume that leaves the site after development, keeping it equal to predevelopment conditions.

Operations & Maintenance manual requirements -To support development, a component of any SWM plan should include the requirement for the designer to complete and provide a report detailing the maintenance recommendations for the proposed SWM system and its components. Site managers and maintenance staff will be able to reference this Operations & Maintenance (O&M) Manual when they have questions about key maintenance tasks, such as sediment removal, valve operation, or capacity for future site expansion.

O&M Manuals should include as-built plans, operating instructions for structures and valves, vegetation lists, vegetation maintenance schedules, and maintenance checklists. As well as clearly outlining the following:

- Inspection frequency of all structures, apertures and functional design elements (minimum of once annually);
- Sediment removal frequency, technique and equipment.
- Method for the re-stabilization of all disturbed areas.
- Sediment testing protocols and method of disposal (if applicable).
- Effluent sampling protocols (if applicable for novel; or un-tested LID approaches).
- LID design life expectancy.
- Replacement/ refurbishment recommendations at the conclusion of LIDs life cycle.